



Qualification Test Plan

AV600-THT



Product Manager	H/W Leader	System Engineer	Testing Engineer
<i>Vinnie Guan</i>	<i>Jimmie Lin</i>	<i>Darrew Chew</i>	<i>Marc Liu</i>

Qualification Test Plan AV600-THT

Version History			
Document Release	Date	Change Item	Remarks
V1.0	07/27/2023	Preliminary release	

System Configuration	
Motherboard	COM Express Type 7+ Carrier board
CPU	Intel® Xeon® W-11865MRE, 2.6(4.7) GHz, 24MB, 45W(35W cTDP), 8C/16T
PCH	Intel® 11 Gen. Tiger Lake integrated Intel® UHD Graphics
RAM1	SO-DIMM DDR4 3200 16GB
RAM2	SO-DIMM DDR4 3200 16GB
GPU	Nvidia A4500 MXM 8GB/16GB GDDR6 CUDA Cores 5888
SATA	2.5" SATA 128GB SSD
DVI	1 x DVI output
LAN	4 x Intel® Gigabit Ethernet
I/O	2 x RS232
USB 2.0/3.0	1 x USB 2.0, 2 x USB3.0
POWER	DC-DC 9V to 36V (250W Max) MIL-STD-461
Dimension	325(D) x 250(W) x 100 (H) mm
Weight	8Kg(13.22lbs)
Chassis	Aluminum Alloy, Corrosion Resistant
Finish	Anodic aluminum oxide
Cooling	Natural Passive Conduction

System Reliability/Environment Test table of Content

1	I/O FUNCTIONAL TEST	5
1-1	POWER BUTTON & LED	5
1-2	X1, X2 (D3VI)	6
1-3	X3 (2 GBE LAN+ 3 USB 2.0)	11
1-4	X4 (4 X RS232/422/485 + 4 BIT DIO)	13
2	AV600X-CH D38999 CONNECTOR	15
3	STRESS CPU/GPU TEST	20
4	USB PERFORMANCE	22
5	LAN PERFORMANCE	24
6	MIL-STD-810G ENVIRONMENTAL ENGINEERING CONSIDERATIONS AND LABORATORY TESTS	26
6-1	LOW PRESSURE (ALTITUDE) TEST	30
6-1-1	Requirements	30
6-1-2	Test Procedure –Storage (Non-Operating)	30
6-1-3	Test Procedure –Operating	30
6-2	HIGH TEMPERATURE TEST	31
6-2-1	Requirements	31
6-2-2	Test Procedure –Storage (Non-Operating)	31
6-2-3	Test Procedure –Operating	33
6-2-4	Acceptance Criteria	34
6-3	LOW TEMPERATURE TEST	35
6-3-1	Requirements	35
6-3-2	Test Procedure	35
6-3-3	Acceptance Criteria	36
6-4	HUMIDITY TEST	37
6-4-1	Requirements	37
6-4-2	Test Procedure	37
6-4-3	Acceptance Criteria	38
6-5	SALT FOG TEST	39
6-5-1	Requirements	39
6-5-2	Test Procedure	39
6-5-3	Acceptance Criteria	39
6-6	SAND & DUST TEST	40
6-6-1	Requirements	40

Qualification Test Plan AV600-THT

6-6-2	Test Procedure	40
6-6-3	Acceptance Criteria	40
6-7	IMMERSION TEST	41
6-7-1	Requirements	41
6-7-2	Test Procedure	41
6-7-3	Acceptance Criteria	42
6-8	VIBRATION TEST	43
6-8-1	Requirements	43
6-8-2	Test Procedure	43
6-8-3	Requirements	43
6-8-4	Test Procedure	43
6-8-5	Requirements	44
6-8-6	Test Procedure	44
6-8-7	Requirements	45
6-8-8	Test Procedure	45
6-8-9	Requirements	46
6-8-10	Test Procedure	46
6-8-11	Acceptance Criteria	46
6-9	SHOCK TEST	47
6-9-1	Requirements	47
6-9-2	Test Procedure	47
6-9-3	Acceptance Criteria	47
6-10	TRANSIT DROP TEST	48
6-10-1	Requirements	48
6-10-2	Test Procedure	48
6-10-3	Acceptance Criteria	48
6-11	BENCH HANDLING TEST	49
6-11-1	Requirements	49
6-11-2	Test Procedure	49
6-11-3	Acceptance Criteria	49

7 MIL-STD-461F REQUIREMENTS FOR THE CONTROL OF ELECTROMAGNETIC INTERFERENCE CHARACTERISTICS OF SUBSYSTEMS AND EQUIPMENT 50

7-1	RE102 TEST	51
7-1-1	Test Procedure	51
7-1-2	Test Configuration	52
7-2	CE102 TEST	54
7-2-1	Requirements	54
7-2-2	Test Procedure	54
7-2-3	Test Configuration	55

Qualification Test Plan AV600-THT

7-3	CS101 TEST	56
7-3-1	Requirements.....	56
7-3-2	Test Procedure	56
7-3-3	Test Configuration	58
7-4	CS114 TEST	59
7-4-1	Requirements.....	59
7-4-2	Test Procedure	59
7-4-3	Test Configuration	60
7-5	CS115 TEST	61
7-5-1	Requirements.....	61
7-5-2	Test Procedure	61
7-5-3	Test Configuration	62
7-6	CS116 TEST	64
7-6-1	Requirements.....	64
7-6-2	Test Procedure	64
7-6-3	Test Configuration	66
7-7	RS103 TEST	67
7-7-1	Requirements.....	67
7-7-2	Test Procedure	67
7-7-3	Test Configuration	68

Qualification Test Plan AV600-THT

I/O FUNCTIONAL TEST

1-1 Power Button & LED



Test Method:

- Connect the POWER BUTTON & power LED,
- Testing the motherboard after pressing the power button.
- Make sure the workable LED light

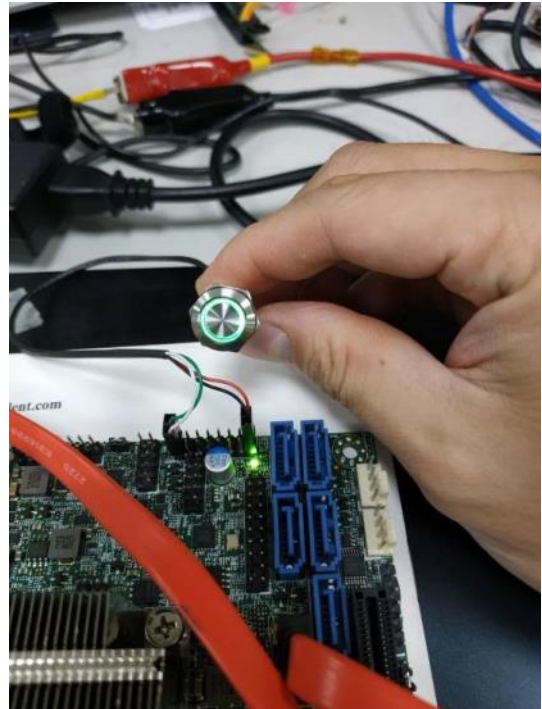

Qualification Test Plan AV600-THT

1-2 X1 (1 x DVI, 2 x COM, USB2.0)



DVI Function Test

DP Test							
Test Method	1. Use 800x600 1024x768 1280x720(or highest solution) and 16&32 bit to test display correctly. 2. Check display with test pattern 3. check display can nothas any cross-color, water wave, and ghost.						
resolution	800x600, 60Hz	800x600, 75Hz	1024x768, 60Hz	1024x768, 75Hz	1280x720, 60Hz	1280x720, 75Hz	1920x1080, 60Hz
DP1	PASS	PASS	PASS	PASS	PASS	PASS	PASS

Graphic Resolution test

Monitor Model	ASUS 27" PB278Q , Maximum resolution : 2560 x 1440 ASUS 23" PA238 , Maximum resolution : 1920 x 1080	
Resolution	DVI 1	DVI 2
640 x 480	✓	✓
720 x 480	✓	✓
720 x 576	✓	✓
800 x 600	✓	✓
1024 x600	✓	✓
1024 x 768	✓	✓
1152 x 648	✓	✓
1152 x 864	✓	✓
1280 x 720	✓	✓

Qualification Test Plan AV600-THT

1280 x 768	✓	✓
1280 x 800	✓	✓
1280 x 1024	✓	✓
1366 x 768	✓	✓
1400 x 1050	✓	✓
1440 x 900	✓	✓
1600 x 900	✓	✓
1600 x 1200	✓	✓
1680 x 1050	✓	✓
1776 x 1000	✓	✓
1920 x 1080	✓	✓
1920 x1200	✓	✓
2560 x 1440	✓	✓

Test Method:

RS-232 COM port test with all Models, Use BEAR CARD to test if RS232 mode works under DOS

DOS mode commends

RS232	RS422	RS485
uart c1 uart c3 \i uart c5 @2xx ixx \i	uart c1 uart c3 \i uart c5 @2xx ixx \i	uart c1 uart c3 \i uart c5 @2xx ixx \i

Test under WINDOWS, using setup_pcommlite_1.6_12041917

SeaCOM_v030602

Qualification Test Plan AV600-THT

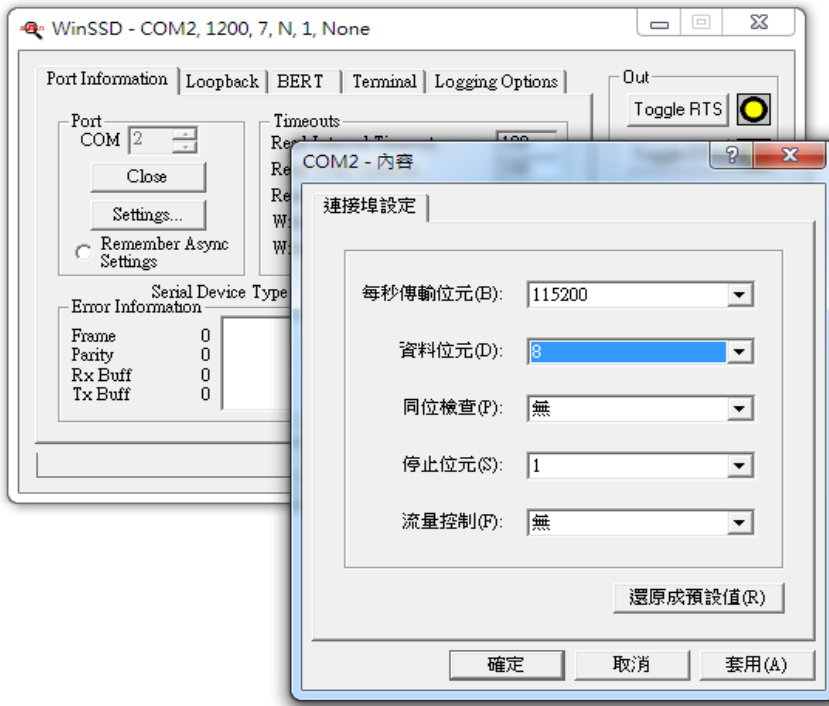

LOOPBACK

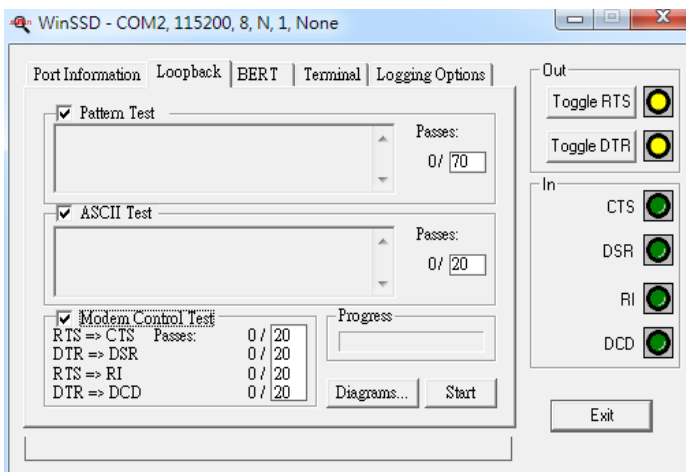

For transmission

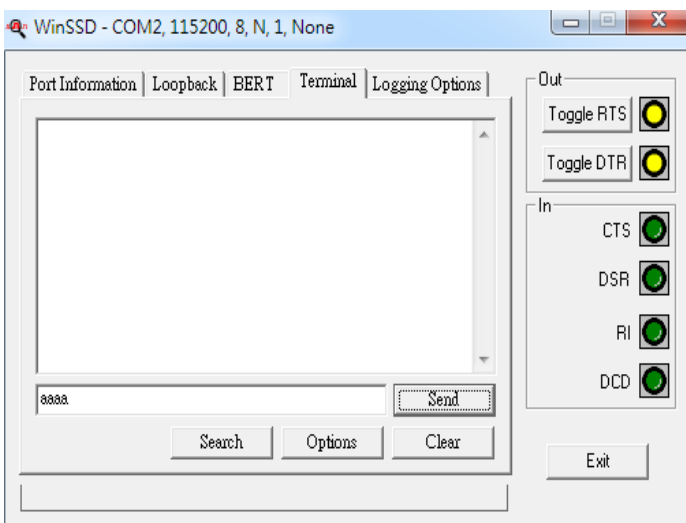

setup_pcommlite

Qualification Test Plan AV600-THT

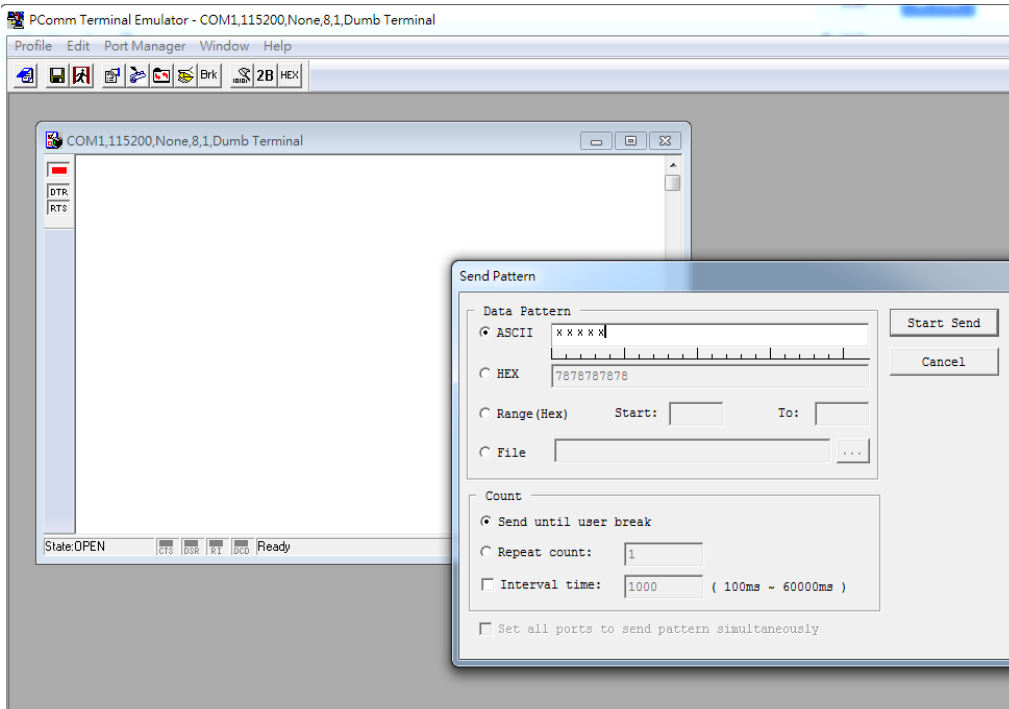
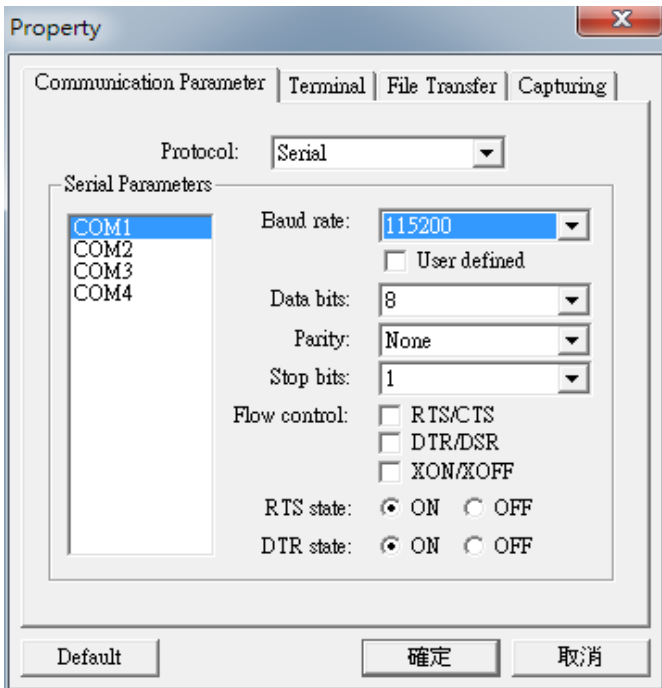

COM PORT STRESS

At least 12 hours, port speed must be set to 115200

Qualification Test Plan AV600-THT

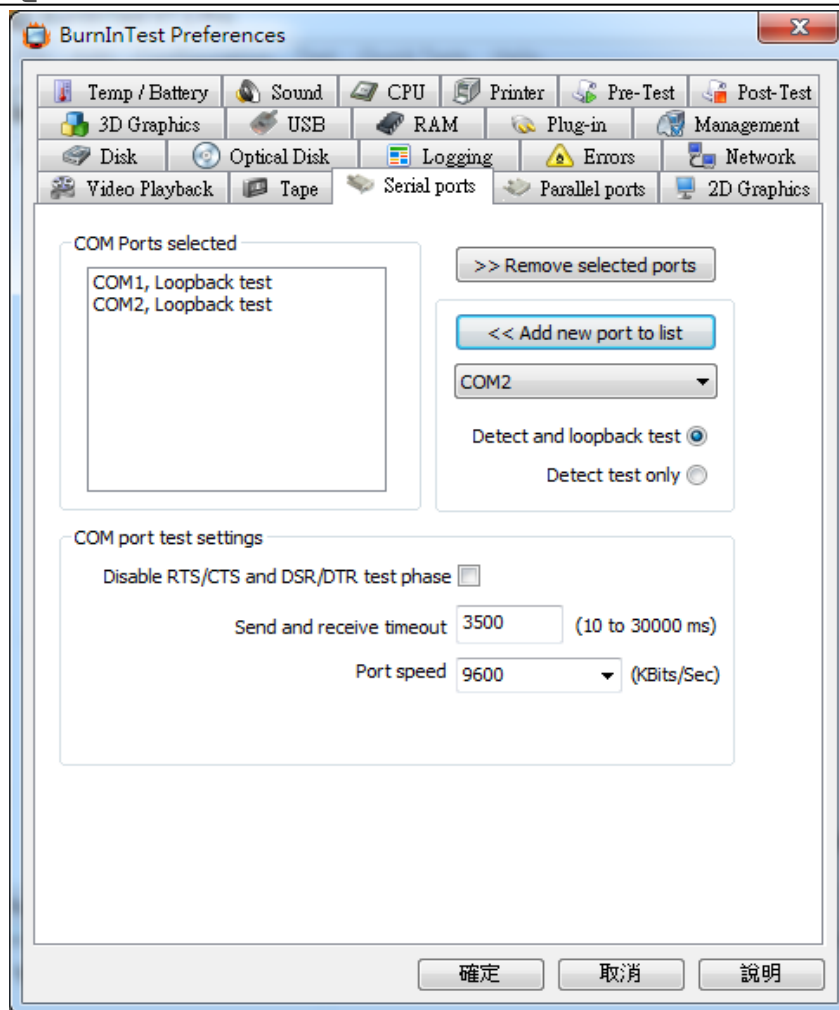

1-3 X2 (4 GbE LAN)



Test Method:

Check the LAN MAC ADDRESS on the MB, LAN SPEED and make sure that you can connect to the Internet

i350 LAN

i350 1Gb LAN-1

```
Administrator: Command Prompt
[280] local 192.168.1.11 port 49210 connected with 192.168.1.33 port 5001
[272] local 192.168.1.11 port 49209 connected with 192.168.1.33 port 5001
[264] local 192.168.1.11 port 49208 connected with 192.168.1.33 port 5001
[256] local 192.168.1.11 port 49207 connected with 192.168.1.33 port 5001
[248] local 192.168.1.11 port 49206 connected with 192.168.1.33 port 5001
[240] local 192.168.1.11 port 49205 connected with 192.168.1.33 port 5001
[232] local 192.168.1.11 port 49204 connected with 192.168.1.33 port 5001
[224] local 192.168.1.11 port 49203 connected with 192.168.1.33 port 5001
[208] local 192.168.1.11 port 49201 connected with 192.168.1.33 port 5001
[216] local 192.168.1.11 port 49202 connected with 192.168.1.33 port 5001
[ ID] Interval Transfer Bandwidth
[240] 0.0- 3.0 sec 42.0 MBytes 117 Mbits/sec
[248] 0.0- 3.0 sec 43.1 MBytes 120 Mbits/sec
[264] 0.0- 3.0 sec 42.3 MBytes 118 Mbits/sec
[224] 0.0- 3.0 sec 42.0 MBytes 117 Mbits/sec
[208] 0.0- 3.0 sec 132 MBytes 365 Mbits/sec
[232] 0.0- 3.0 sec 7.98 MBytes 22.1 Mbits/sec
[280] 0.0- 3.0 sec 8.35 MBytes 23.2 Mbits/sec
[272] 0.0- 3.0 sec 8.23 MBytes 22.8 Mbits/sec
[216] 0.0- 3.0 sec 7.83 MBytes 21.7 Mbits/sec
[256] 0.0- 3.0 sec 8.04 MBytes 22.3 Mbits/sec
[SUM] 0.0- 3.0 sec 341 MBytes 947 Mbits/sec
C:\>
```

Qualification Test Plan AV600-THT

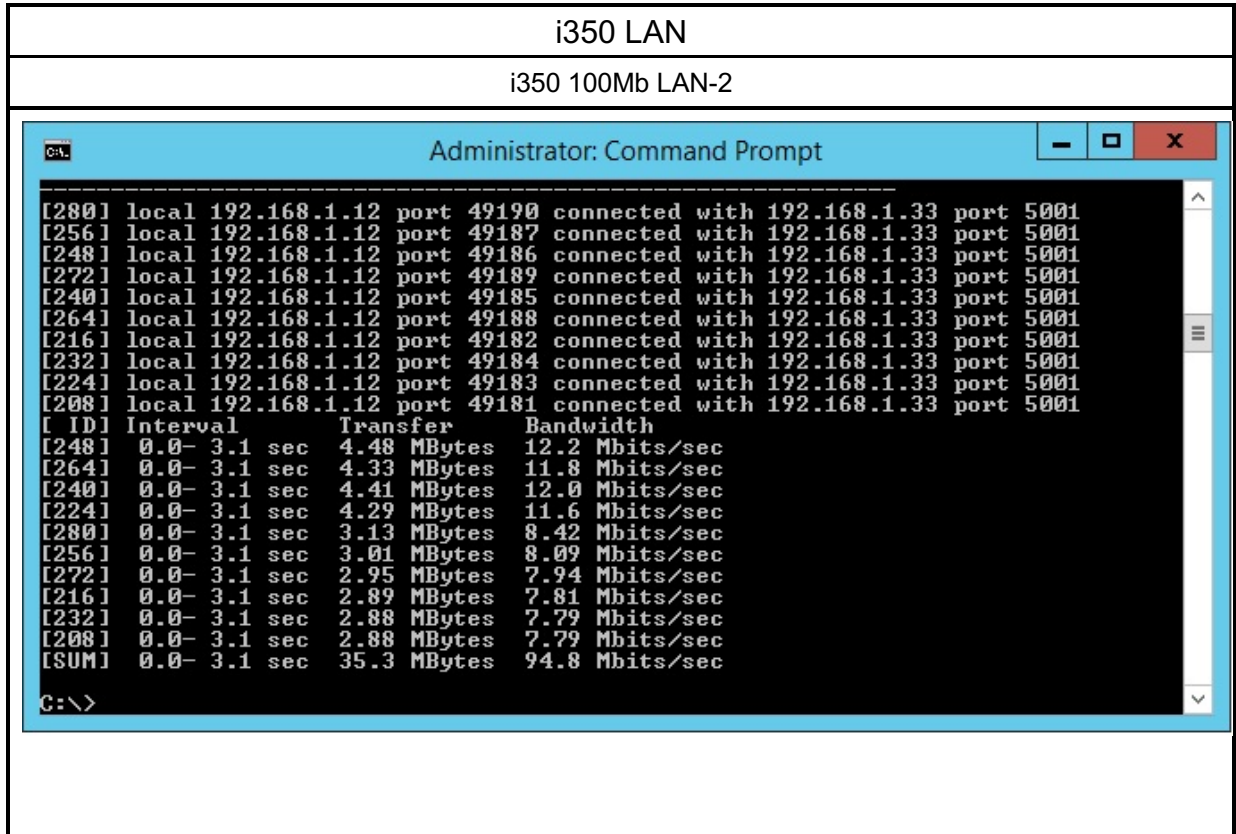

LAN STRESS

At least 12 hours

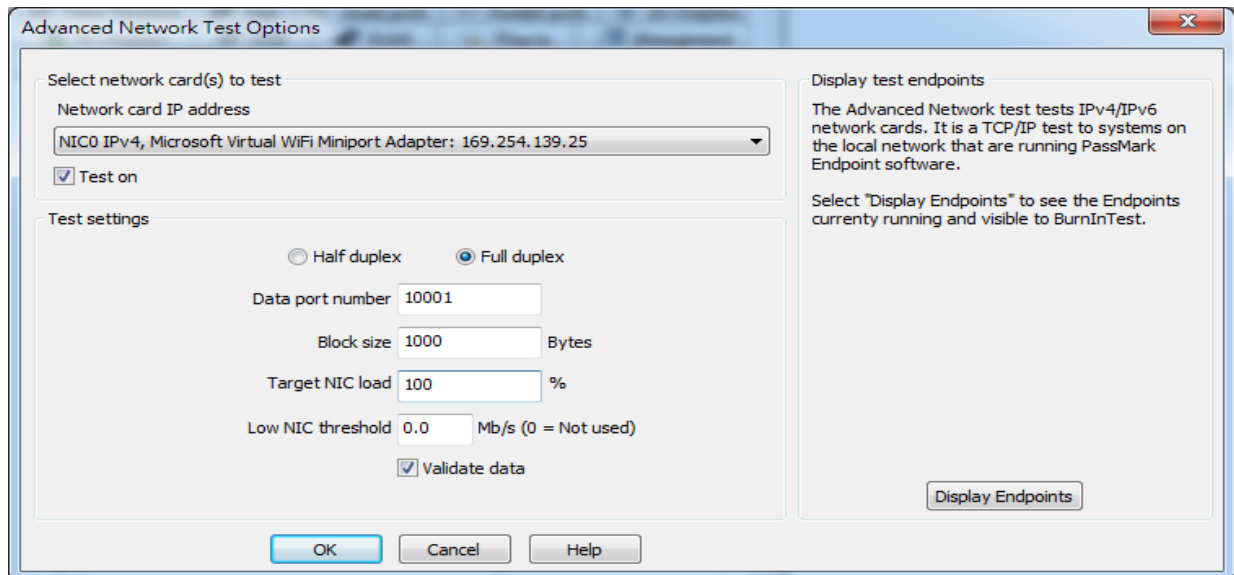

Qualification Test Plan AV600-THT

1-4 X3-X4 (USB 3.0)



Test Method:

Check if we can detect the USB,2xpin header & real connector x2 with USB DEVICE

Loopback Plugs for USB 3.0 & USB2.0

Software	Comment / (unit)	connector	Read / Write (Mb/s)	Result	Note
PassMark Software	PassMark USB3.0 test plug	USB3.0-1	2004/2112		
		USB3.0-2	2023/2114		
	PassMark USB2.0 test plug	USB2.0-1	393/360 (Mb/s)		

USB3.0-1

Results Status: BENCHMARK test - Complete
 Duration: 000h 30m 43s Operations: 0 Verification errors: 0
 Max. Rate: 2794
 Voltage: 5.05V Speed: 5Gb/s

OVERALL BENCHMARK RESULT:
 Test Start time: Thu May 23 17:05:48 2019
 Duration: 000h 30m 43s
 Maximum Write Data Rate: 2794.9 Mb/s
 Maximum Read Data Rate: 2387.0 Mb/s
 Average Write Data Rate: 2112.9 Mb/s
 Average Read Data Rate: 2004.1 Mb/s
 Average Data Rate: 2057.1 Mb/s
 Minimum Data Rate: 781.4 Mb/s

USB3.0-2

Results Status: BENCHMARK test - Complete
 Duration: 000h 30m 44s Operations: 0 Verification errors: 0
 Max. Rate: 2809
 Voltage: 5.06V Speed: 5Gb/s

OVERALL BENCHMARK RESULT:
 Test Start time: Thu May 23 17:05:53 2019
 Duration: 000h 30m 44s
 Maximum Write Data Rate: 2809.4 Mb/s
 Maximum Read Data Rate: 2396.1 Mb/s
 Average Write Data Rate: 2114.2 Mb/s
 Average Read Data Rate: 2023.7 Mb/s
 Average Data Rate: 2067.9 Mb/s
 Minimum Data Rate: 909.5 Mb/s

USB2.0-1

Qualification Test Plan AV600-THT

PassMark(TM) USB2Test

Select USB test:
 Test mode: Loopback Benchmark
 Loopback load: %
 Device: PMUSB-0 (480Mb/s)
 Duration: Minutes (0=forever)

USB test data selection:
 Constant (default)
 Incrementing sequence
 Random numbers
 Verify data transferred

Results for PMUSB-0 (USB 2.0) Status: Benchmark test - Complete

Duration: 000h 30m 12s Operations: 14535 Verification errors: 0

Operation ID	Max. Rate (Mb/s)	Ave. Rate (Mb/s)	Min. Rate (Mb/s)
14519	360	334	328
14520	360	347	328
READING FROM USB DEVICE (32768 byte blocks).			
14521	393	387	360
14522	393	393	393
14523	393	393	393
14524	393	385	360
14525	393	393	393
14526	393	393	393
14527	393	385	360
14528	393	385	360
14529	393	393	393
14530	393	387	360
WRITING TO USB DEVICE (32768 byte blocks).			
14531	360	341	328
14532	360	341	328
14533	360	354	328
14534	360	334	328

Max. Rate: 393 (Mb/s)

Buttons: Start, Stop, Save Log, Reset All, About, Help, Exit

Qualification Test Plan AV600-THT

2 AV600-THT D38999 CONNECTOR

INDEX

1. X1 DVI. 2xCOM, USB2.0 AMPHENOL 26JD35PA
 2. X2 4 x GLAN AMPHENOL 26JD35PN
 3. X3 USB 3.0 AMPHENOL USB3FTV7AxF312
 4. X4 USB 3.0 AMPHENOL USB3FTV7AxF312
- DC-IN AMPHENOL 26FB5SN

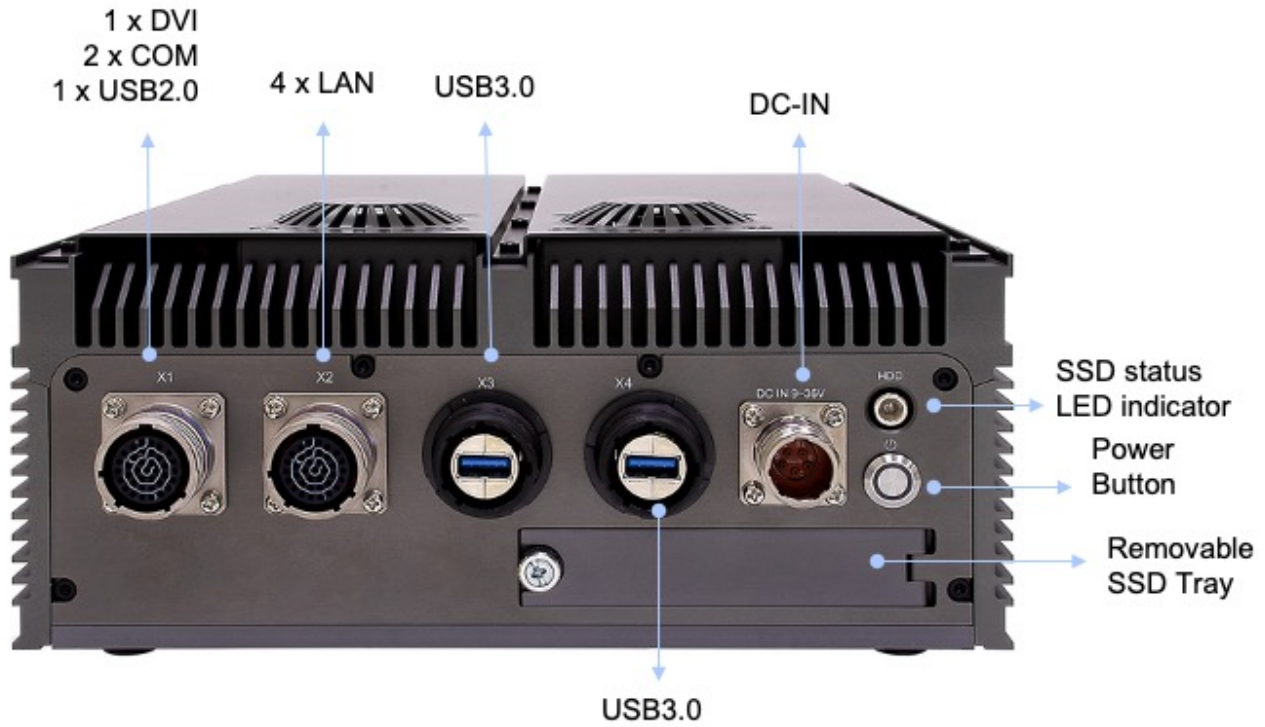

AV600-THT DC-IN D38999 Cable

	D38999	Pin define	
<p>Power EXT</p>	A	(+)	TN1
	B	(+)	
	E	(-)	TN2
	D	(-)	
	SHELL	G	O Plug



Qualification Test Plan AV600-THT

AV600-THT X1 EXT-DVI AND VGA CABLE

SYSTEM	D38	Pin define	CON2	CON3
	1	DPA_TN0	1	
	2	DPA_TP0	2	
	3	GND	3	
	4	DPA_AUXP_CLK(p)	23	
	5	DPA_AUXP_CLK(n)	24	
	6	GND	22	
	7	DPA_TN1	9	
	8	DPA_TP1	10	
	9	GND	11	
	10	DPA_PWR	14	
	11	Return GND	15	
	12	DPA_DET	16	
	13	DPA_TN2	17	
	14	DPA_TP2	18	
	15	GND	19	
	16	CLOCK Shield		
	17	DPA_TP3	6	
	18	DPA_TN3	7	
	19	GND	shell	
	20			
	21	VS		14
	22	SCL		15
	23	HS		13
	24	SDA		12
	25	GND		10/5
	26	PWR		9
	27	RED		1
	28	BLUE		3
	29	GREEN		2
	30			
	31			
	32			
	33			
	34			
	35			
	36			
	37			



Qualification Test Plan AV600-THT

AV600-THT X1 EXT-DVI AND VGA CABLE

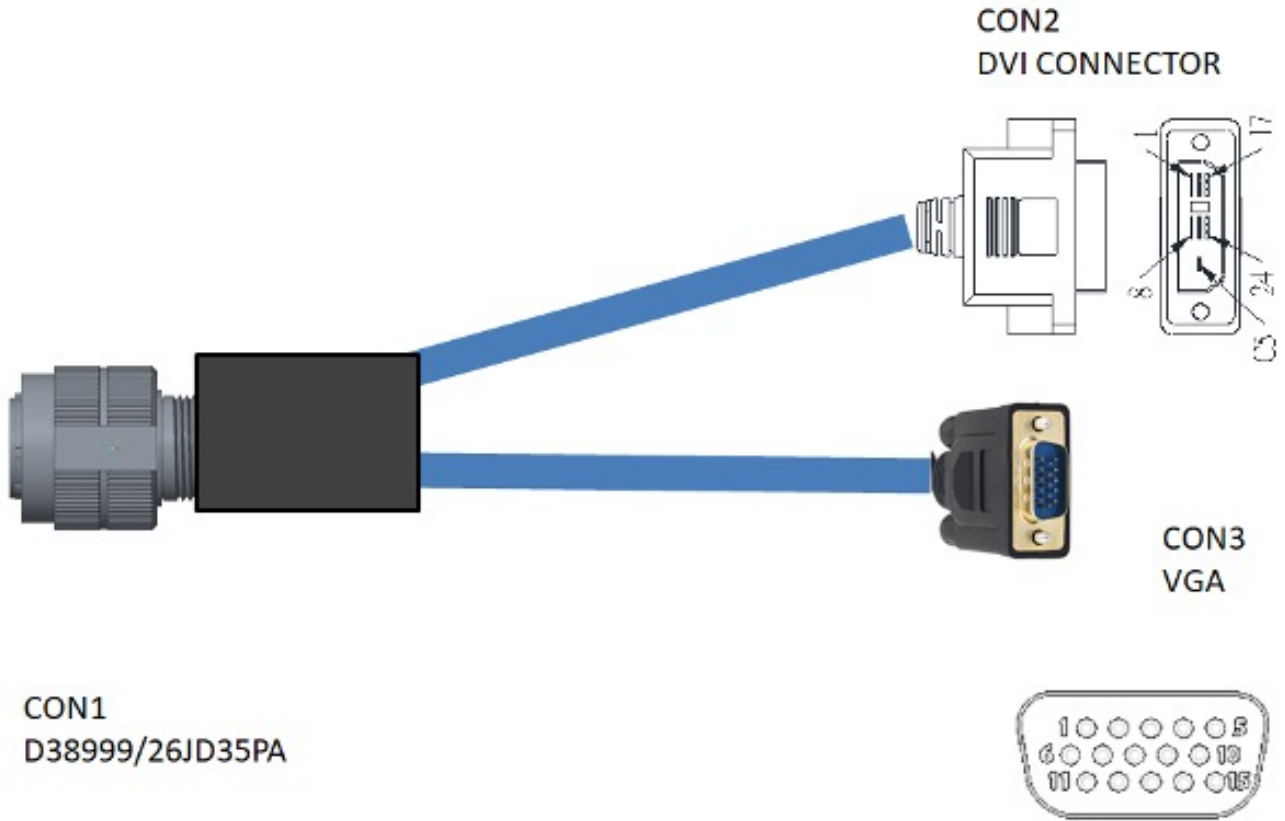

Qualification Test Plan AV600-THT

AV600-THT X2 EXT-LAN and COM CABLE

SYSTEM	D38999	Pin define	CON2	CON3	CON4
	1	WHITE / ORANGE	1		
	2	ORANG	2		
	3	WHITE / GREEN	3		
	4	GREEN	6		
	5	WHITE / BLUE	5		
	6	BLUE	4		
	7	WHITE / BROWN	7		
	8	BROWN	8		
	9	WHITE / ORANGE		1	
	10	ORANG		2	
	11	WHITE / GREEN		3	
	12	GREEN		6	
	13	WHITE / BLUE		5	
	14	BLUE		4	
	15	WHITE / BROWN		7	
	16	BROWN		8	
	17				
	18				
	19				
	20				
	21	DCD			1
	22	RXD			2
	23	TXD			3
	24	DTR			4
	25	GND			5
	26	DSR			6
	27	RTS			7
	28	CTS			8
	29	RI			9
	30				
	31				
	32				
	33				
	34				
	35				
	36				
	37				



Qualification Test Plan AV600-THT

AV600-THT X2 EXT-LAN and COM CABLE

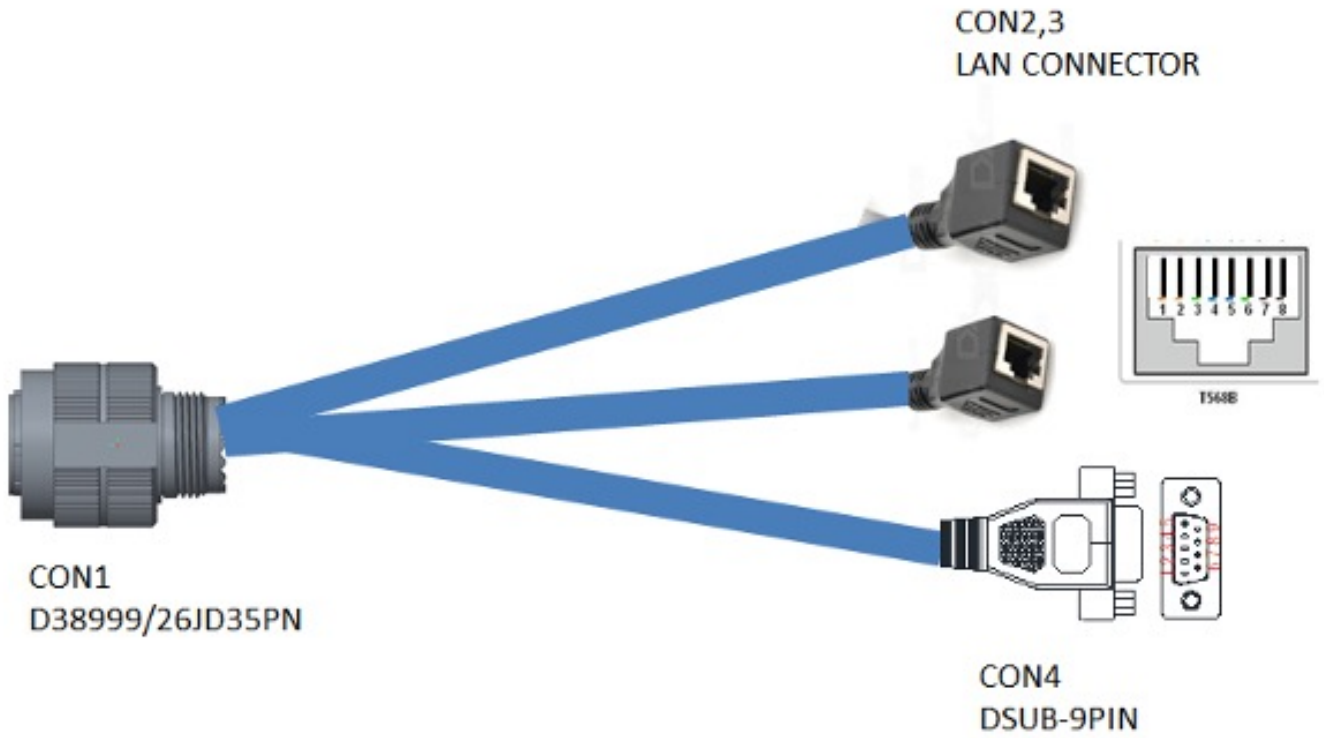

Qualification Test Plan AV600-THT

3 STRESS CPU/GPU TEST

HeavyLoad is intended to stress all resources of a PC (CPU, GPU, RAM, hard disk, network, operating system etc.) in order to test if it will run reliably under heavy load. This is useful for assessing important file or database servers before using them productively, or simply to ensure your new PC will not overheat or crash when used intensively.

The program also allows testing the behavior of systems under fading system resources (memory, disk space).

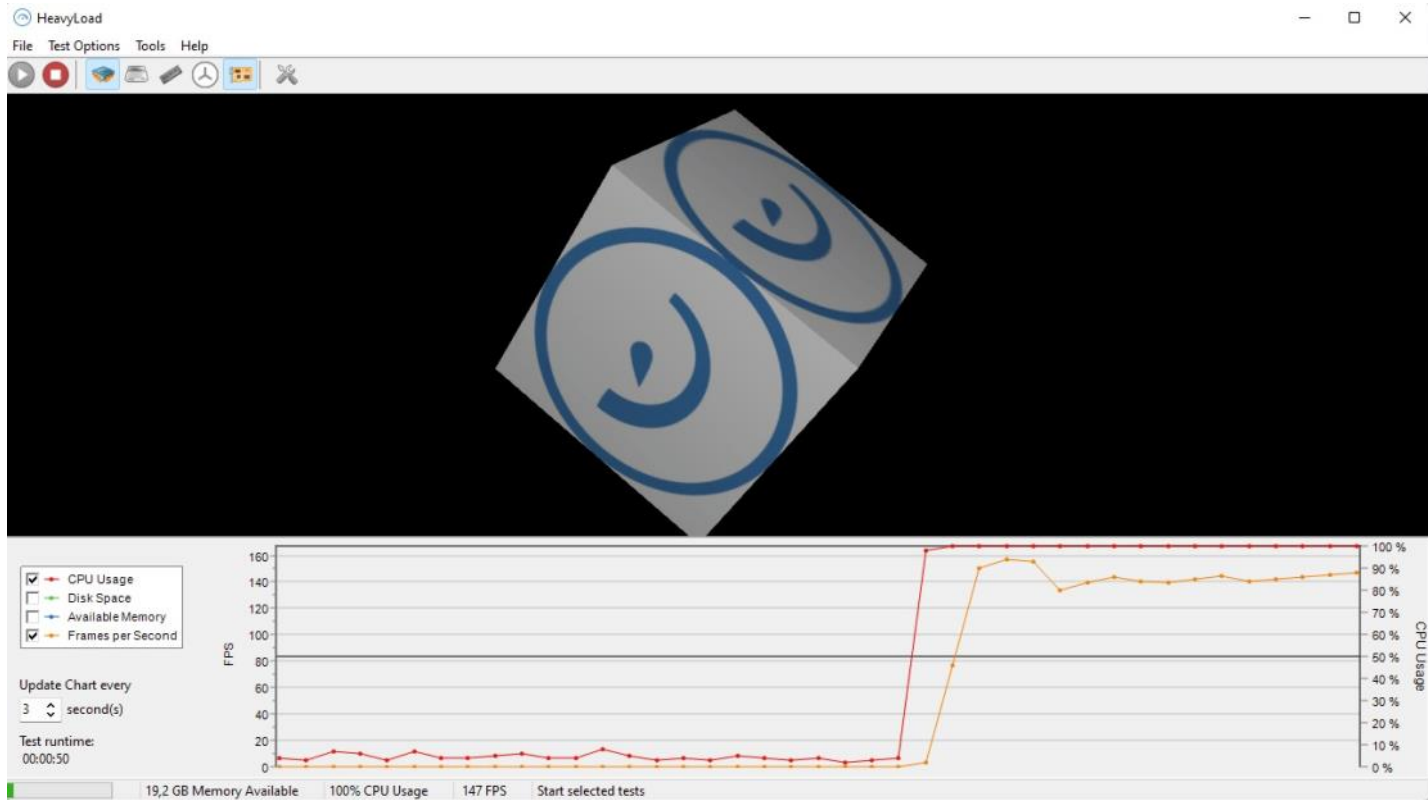

Qualification Test Plan AV600-THT

● Stress CPU

Use your processor or even a specific number of processor cores to full capacity. HeavyLoad performs complex calculations to simulate the load on your processor. 0~100%

CPU Options

Used logical processors

Allows to set the number of used logical processors for the CPU stress test if the system has more than one. The default number is set to the maximum amount of available processors (physical and virtual cores) on your system.

Thread Options

Thread priority

Allows to define the priority at which the threads are running. This can be used to precisely control the system utilization of HeavyLoad. "Idle" means the CPU will only be used if no other threads are using it. Choosing a higher priority will result in the stress threads having a higher priority than the thread of the user interface, which may result in the user interface being unresponsive during the tests.

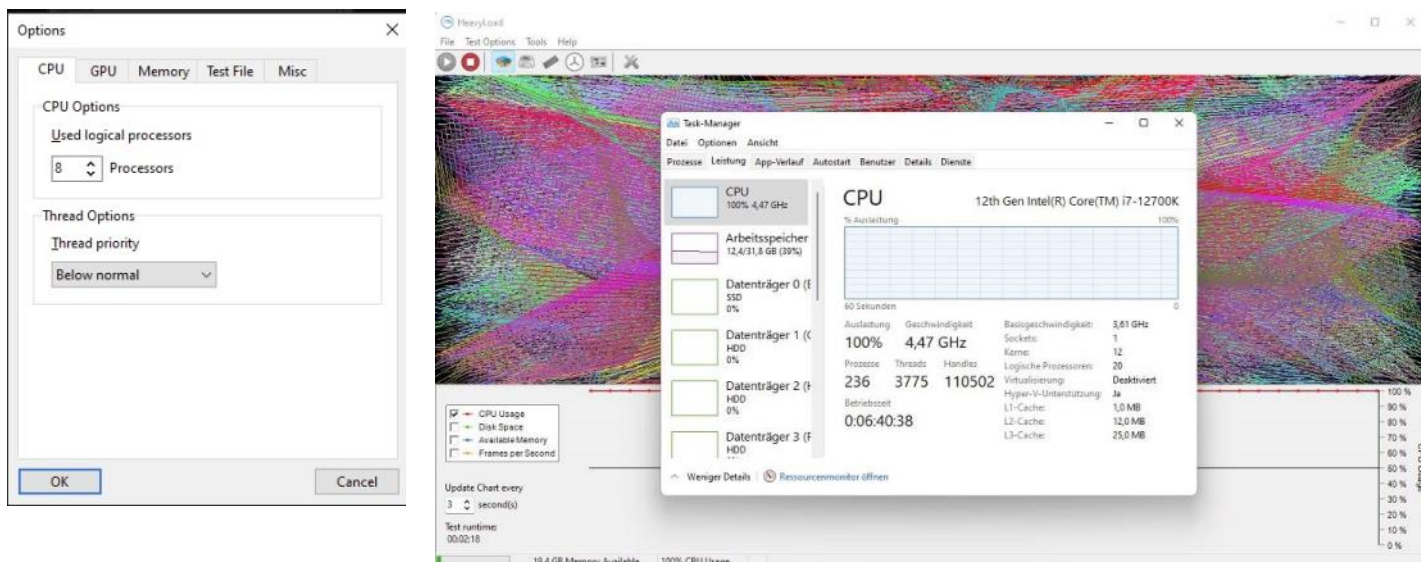

● Stress GPU

HeavyLoad you can utilize your graphics card processor to capacity. HeavyLoad employs a 3D rendered graphic to simulate a high load on the GPU.

Qualification Test Plan AV600-THT

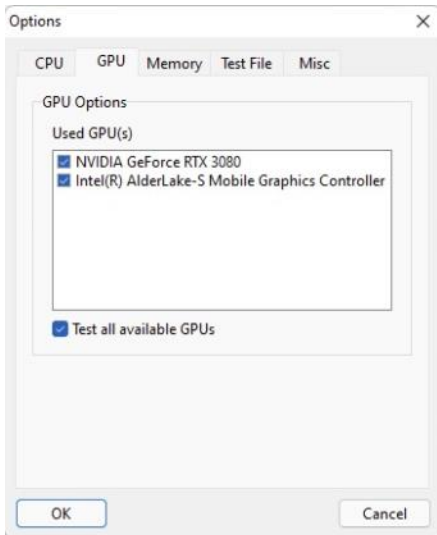

4 USB PERFORMANCE

Loopback Plugs for USB 3.0 & USB2.0

Software	Comment / (unit)	connector	Read / Write (Mb/s)	Result	Note
PassMark Software	PassMark USB3.0 test plug	USB3.0-1	2004/2112		
		USB3.0-2	2023/2114		
	PassMark USB2.0 test plug	USB2.0-1	393/360 (Mb/s)		

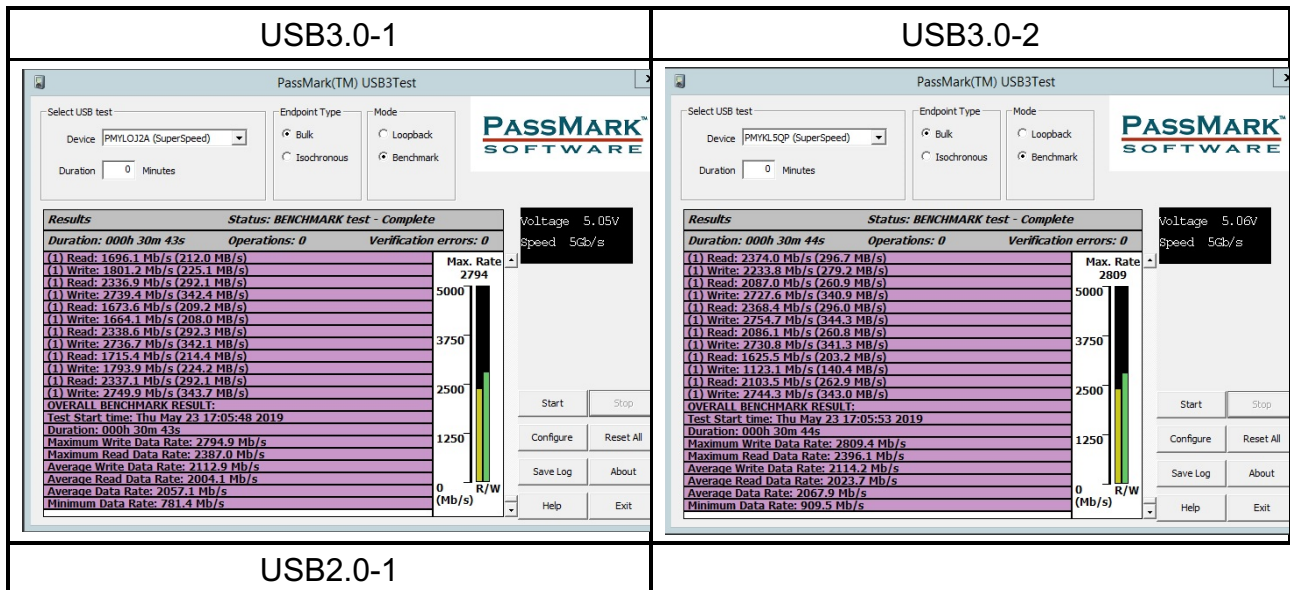

Qualification Test Plan AV600-THT

The screenshot shows the PassMark(TM) USB2Test application window. The interface is divided into several sections:

- Test Configuration:**
 - Select USB test:** Test mode is set to **Benchmark**. Loopback load is at **100%**. Device is **PMUSB-0 (480Mb/s)**. Duration is **0** minutes.
 - USB test data selection:** **Constant (default)** is selected with a value of **0**. Other options include **Incrementing sequence**, **Random numbers**, and **Verify data transferred** (checked).
- Results for PMUSB-0 (USB 2.0) Status: Benchmark test - Complete**
 - Duration:** 000h 30m 12s
 - Operations:** 14535
 - Verification errors:** 0

Operation ID	Max. Rate (Mb/s)	Ave. Rate (Mb/s)	Min. Rate (Mb/s)
14519	360	334	328
14520	360	347	328
READING FROM USB DEVICE (32768 byte blocks).			
14521	393	387	360
14522	393	393	393
14523	393	393	393
14524	393	385	360
14525	393	393	393
14526	393	393	393
14527	393	385	360
14528	393	385	360
14529	393	393	393
14530	393	387	360
WRITING TO USB DEVICE (32768 byte blocks).			
14531	360	341	328
14532	360	341	328
14533	360	354	328
14534	360	334	328
- Performance Graph:** A bar chart on the right shows the maximum rate for each operation, with a peak of 393 Mb/s. The y-axis is labeled 'Max. Rate (Mb/s)' and ranges from 0 to 480. The x-axis is labeled 'R/W'.
- Controls:** Buttons for **Start**, **Stop**, **Save Log**, **Reset All**, **About**, **Help**, and **Exit** are located at the bottom.

Qualification Test Plan AV600-THT

5 LAN PERFORMANCE

Test Method	LAN Speed must working follow setting speed in OS.	
	i350 LAN-1	i350 LAN-2
iperf test speed (Mbps)	947 Mb/s	94.8 Mb/s

i350 LAN

i350 1Gb LAN-1

```

Administrator: Command Prompt
-----
[280] local 192.168.1.11 port 49210 connected with 192.168.1.33 port 5001
[272] local 192.168.1.11 port 49209 connected with 192.168.1.33 port 5001
[264] local 192.168.1.11 port 49208 connected with 192.168.1.33 port 5001
[256] local 192.168.1.11 port 49207 connected with 192.168.1.33 port 5001
[248] local 192.168.1.11 port 49206 connected with 192.168.1.33 port 5001
[240] local 192.168.1.11 port 49205 connected with 192.168.1.33 port 5001
[232] local 192.168.1.11 port 49204 connected with 192.168.1.33 port 5001
[224] local 192.168.1.11 port 49203 connected with 192.168.1.33 port 5001
[208] local 192.168.1.11 port 49201 connected with 192.168.1.33 port 5001
[216] local 192.168.1.11 port 49202 connected with 192.168.1.33 port 5001
[ ID] Interval      Transfer      Bandwidth
[240] 0.0- 3.0 sec  42.0 MBytes  117 Mbits/sec
[248] 0.0- 3.0 sec  43.1 MBytes  120 Mbits/sec
[264] 0.0- 3.0 sec  42.3 MBytes  118 Mbits/sec
[224] 0.0- 3.0 sec  42.0 MBytes  117 Mbits/sec
[208] 0.0- 3.0 sec  132 MBytes  365 Mbits/sec
[232] 0.0- 3.0 sec   7.98 MBytes  22.1 Mbits/sec
[280] 0.0- 3.0 sec   8.35 MBytes  23.2 Mbits/sec
[272] 0.0- 3.0 sec   8.23 MBytes  22.8 Mbits/sec
[216] 0.0- 3.0 sec   7.83 MBytes  21.7 Mbits/sec
[256] 0.0- 3.0 sec   8.04 MBytes  22.3 Mbits/sec
[SUM] 0.0- 3.0 sec  341 MBytes  947 Mbits/sec
C:\>
    
```

i350 LAN

i350 100Mb LAN-2

Qualification Test Plan AV600-THT

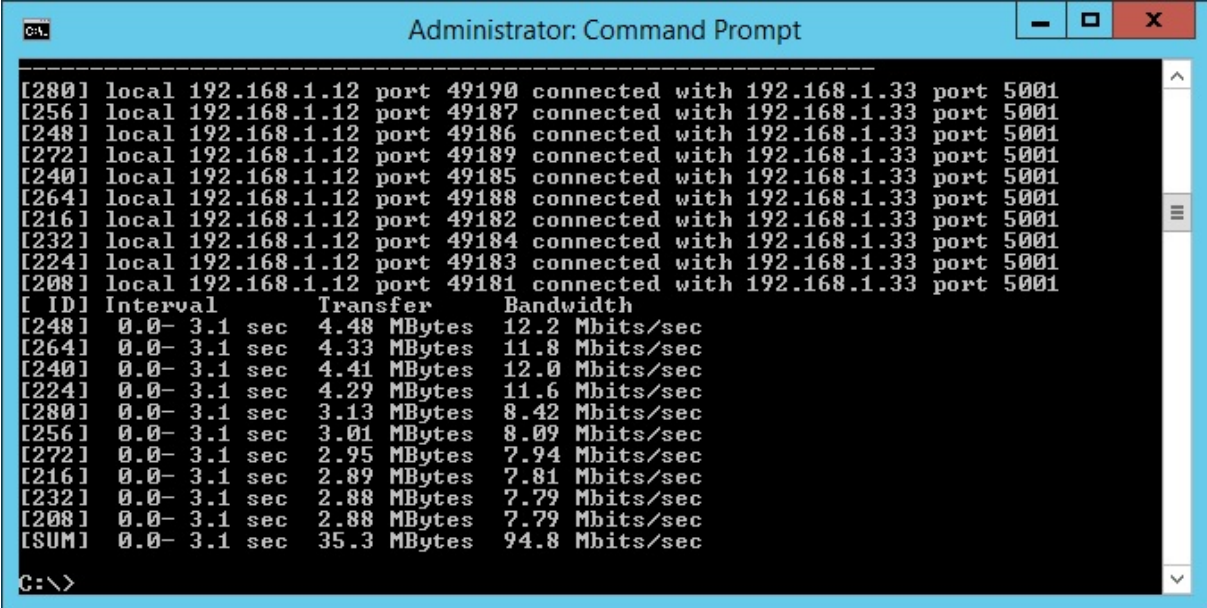

```
Administrator: Command Prompt

[280] local 192.168.1.12 port 49190 connected with 192.168.1.33 port 5001
[256] local 192.168.1.12 port 49187 connected with 192.168.1.33 port 5001
[248] local 192.168.1.12 port 49186 connected with 192.168.1.33 port 5001
[272] local 192.168.1.12 port 49189 connected with 192.168.1.33 port 5001
[240] local 192.168.1.12 port 49185 connected with 192.168.1.33 port 5001
[264] local 192.168.1.12 port 49188 connected with 192.168.1.33 port 5001
[216] local 192.168.1.12 port 49182 connected with 192.168.1.33 port 5001
[232] local 192.168.1.12 port 49184 connected with 192.168.1.33 port 5001
[224] local 192.168.1.12 port 49183 connected with 192.168.1.33 port 5001
[208] local 192.168.1.12 port 49181 connected with 192.168.1.33 port 5001
[ ID] Interval      Transfer      Bandwidth
[248] 0.0- 3.1 sec   4.48 MBytes   12.2 Mbits/sec
[264] 0.0- 3.1 sec   4.33 MBytes   11.8 Mbits/sec
[240] 0.0- 3.1 sec   4.41 MBytes   12.0 Mbits/sec
[224] 0.0- 3.1 sec   4.29 MBytes   11.6 Mbits/sec
[280] 0.0- 3.1 sec   3.13 MBytes   8.42 Mbits/sec
[256] 0.0- 3.1 sec   3.01 MBytes   8.09 Mbits/sec
[272] 0.0- 3.1 sec   2.95 MBytes   7.94 Mbits/sec
[216] 0.0- 3.1 sec   2.89 MBytes   7.81 Mbits/sec
[232] 0.0- 3.1 sec   2.88 MBytes   7.79 Mbits/sec
[208] 0.0- 3.1 sec   2.88 MBytes   7.79 Mbits/sec
[SUM] 0.0- 3.1 sec   35.3 MBytes   94.8 Mbits/sec

C:\>
```

Qualification Test Plan AV600-THT

6 MIL-STD-810G ENVIRONMENTAL ENGINEERING CONSIDERATIONS AND LABORATORY TESTS

The AV600-THT shall be tested under the environmental conditions as defined by MIL-STD-810G and MIL-HDBK-454, as detailed in Table 1

Table 1: List of Tests

#	Test	Spec' as Internal	Conditions
		Equipment	
1	Low Pressure (Altitude)	MIL-STD-810G, Method 500.5 & Procedure I, Storage	Altitude not operational Storage/Air Transport -- The system shall not be damaged nor its performance degraded during and after exposure to environment of 15,000 feet altitude and exposed to +71°C and -33°C (absolute pressure of 55KPa),
		MIL-STD-810G, Method 500.5 & Procedure I, Storage	Altitude not operational Storage/Ground Transport -- The system shall not be damaged nor its performance degraded during and after exposure to environment of -400m to 2500m altitude and exposed to +71°C and -20°C
		MIL-STD-810G, Method 500.5 & Procedure II, Operating mode	Altitude operation ground -- The system shall not be damaged nor its performance degraded during and after exposure to -200+2500[m] ground operation and exposed to +55°C and -20°C
2	High Temperature	MIL-STD-810G, Method 501.5, Procedure I & II Storage & Operation	High Temperature Storage -- +71°C per MIL-STD-810G/501.5/I for 7 cycles High Temperature Operation -- +55°C per MIL-STD-810G/501.5/II for 3 cycles
3	Low Temperature	MIL-STD-810G, Method 502.5, Procedure I & II Storage & Operation	Low Temperature Storage -- -33°C for 72 hours Low Temperature operation -- The minimum steady operational temperature is -20°C with design goal of -33°C according to Figure 2. The system shall be in operational mode during temperature rise time (-33°C+25°C) and should be tested at 0°C and 25°C
4	Humidity	MIL-STD-810G, Method 507.5, Procedure II (Aggravated), Constant high Humidity – B1	exposure to 10 cycles of 95% relative humidity at temperatures of 30 °C to 60 °C.
5	Salt Fog	MIL-STD-810G, Method 509.5	5% NaCl @35°C, 95% relative humidity 24hrs of exposure followed by 24hrs Drying less than 50% relative humidity, 2 cycles
6	Sand & Dust	MIL-STD-810G, Method 501.5	The system shall survive without any damage or degradation of performance and should operate to specification during and after exposure to blowing dust test according to MIL-STD-810G/510.5/I. Test parameters: <ul style="list-style-type: none"> Dust particle size: <150µm. Dust concentration: 10.6 gr/m3 Wind speed: 8.9 m/s.
7	Immersion	Method 512.5	The system shall survive without any damage or degradation of performance and should operate to specification after exposure to sealing test according to IEC 60529/ IP65.

Qualification Test Plan AV600-THT

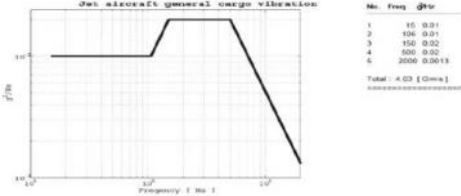
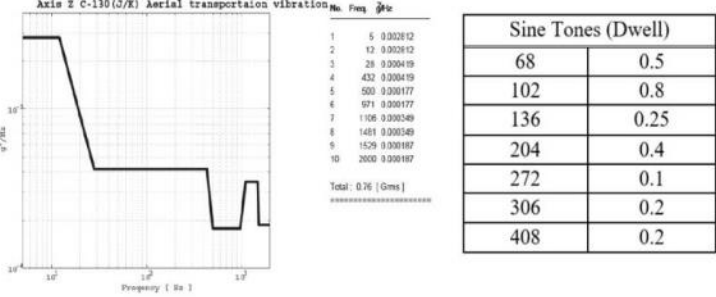
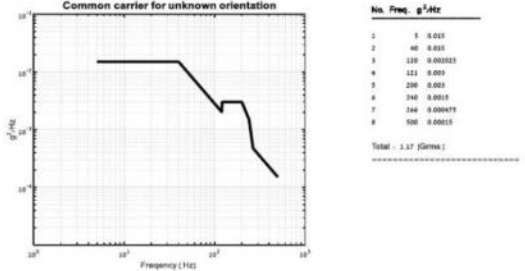
#	Test	Spec' as Internal Equipment	
		Spec' as Internal Equipment	Conditions
8	Vibrations	MIL-STD-810G/514.6	<p>Packaged components by commercial aircraft -- Test duration: 20 minutes per axis (x,y,z) to simulate 20 landings and takeoffs. This test shall be performed using reusable dedicated ruggedized package for spare parts.</p>  <p>Figure 3: Jet Cargo Aircraft Vibration</p>
			<p>C-130(J/K) aircraft -- Test duration 400 minutes per axis (x,y,z), simulating 120 flight hours including 20 landings and takeoffs.</p>  <p>Figure 4: For unknown orientation axis- C-130(J/K) Aerial Transportation Vibration</p>
8	Vibrations		<p>Ground Transportation (Packaged) – Common Carrier -- MIL-STD-810H method 514.8 category 4. Test duration: 190 minutes per axis to simulate 5000 km of driving distance. This test shall be performed using reusable dedicated ruggedized package for spare parts.</p>  <p>Figure 5: Common Carrier Vibration Profile for unknown orientation</p>

Qualification Test Plan AV600-THT

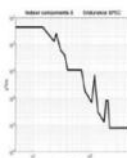
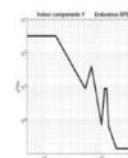
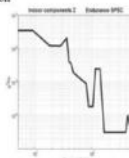
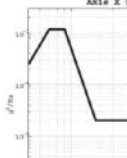
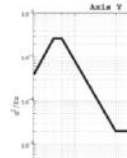
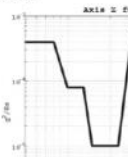
#	Test	Spec' as Internal Equipment											
		Spec' as Internal Equipment	Conditions										
			   <p>Tactical Transportation – Not Operational -- Test duration: 100 minutes per axis to simulate 500,000 km driving distance. Coordinate system according to Figure 1</p>										
9	Vibrations	MIL-STD-810G/514.6	<p>Functional Vibration -- Test duration: completion of functional test. Coordinate system according to Figure 1.</p>    <p>Figure 9: Axis X Tactical Functional Vibration</p> <p>Figure 10: Axis Y Tactical Functional Vibration</p> <p>Figure 11: Axis Z Tactical Functional Vibration</p>										
10	Shock	MIL-STD-810G, Method 516.6	<p>Road Transportation -- Test parameters:</p> <table border="1"> <thead> <tr> <th>Axis</th> <th>G peak [g]</th> <th>Duration [ms]</th> <th>Pulse</th> <th>Amount</th> </tr> </thead> <tbody> <tr> <td>XYZ</td> <td>10</td> <td>11</td> <td>Sawtooth</td> <td>3 in each direction</td> </tr> </tbody> </table> <p>Transit Drop (Packaged Components) -- All components shall survive without any damage or degradation of performance and should operate to specification after exposure to transit drops experienced during logistic transportation according to MIL-STD 810G CH1 method 516.6 procedure IV table 516.7-VII. This test shall be performed using reusable dedicated ruggedized package for spare parts.</p> <p>Bench Handling -- Large components shall survive without any damage or degradation of performance and should</p>	Axis	G peak [g]	Duration [ms]	Pulse	Amount	XYZ	10	11	Sawtooth	3 in each direction
Axis	G peak [g]	Duration [ms]	Pulse	Amount									
XYZ	10	11	Sawtooth	3 in each direction									

Qualification Test Plan AV600-THT

#	Test	Spec' as Internal Equipment	Conditions
			operate to specification after exposure to bench handling shocks according to MIL-STD 810G method 516.6/ VI.





Qualification Test Plan AV600-THT

6-1 LOW PRESSURE (ALTITUDE) TEST

6-1-1 Requirements

Perform the Low Pressure (Altitude) test in accordance with MIL-STD-810G Method 500.5 Procedures I with the following parameters:

Storage (Air-Transport)

 Temperature Range	-33°C to +71°C	 Altitude	15000 feet
 Pressure	55Kpa		

Storage (Ground-Transport)

 Temperature Range	-20°C to +71°C	 Ground	-400+2500[m]
---	----------------	--	--------------

Operation Ground

 Temperature Range	-20°C to +55°C	 Ground	-200+2500[m]
---	----------------	--	--------------

6-1-2 Test Procedure –Storage (Non-Operating)

- Step 1. At ambient condition perform a visual and functional test per [Subject]
- Step 2. Document the results.
- Step 3. Insert the AV600-THT in the test facility.
- Step 4. Prepare the AV600-THT in its storage configuration.
- Step 5. At completion of the test adjust the chamber air temperature to ambient conditions until temperature stabilization of the AV600-THT
- Step 6. Document the results.

6-1-3 Test Procedure –Operating

- Step 1. At ambient condition perform a visual and functional test per [Subject]
- Step 2. Document the results.
- Step 3. Insert the AV600-THT in the test facility.
- Step 4. Prepare the AV600-THT in its storage configuration.
- Step 5. At completion of the test adjust the chamber air temperature to ambient conditions until temperature stabilization of the AV600-THT.
- Step 6. Document the results.

Qualification Test Plan AV600-THT

6-2 HIGH TEMPERATURE TEST

6-2-1 Requirements

Perform the high temperature test in accordance with MIL-STD-810G Method 501.5 Procedures I & II with the following parameters:

Storage (Non-Operating)

🌡️ Temperature Range	+33°C to +71°C	🕒 Cycle Duration	24 hrs.
🔄 Cycles	7	📦 Item condition	Unpacked

Operation:

🌡️ Temperature Range	+33°C to +55°C	🕒 Cycle Duration	24 hrs.
🔄 Cycles	3	📦 Item condition	Unpacked

6-2-2 Test Procedure –Storage (Non-Operating)

- Step 1. At ambient condition perform a visual and functional test per [Subject]
- Step 2. Document the results.
- Step 3. Insert the AV600-THT in the test facility.
- Step 4. Prepare the AV600-THT in its storage configuration.
- Step 5. Expose the AV600-THT to 7 cycles (duration of 24 hours each cycle) of storage high temperature as described.
- Step 6. At completion of the test adjust the chamber air temperature to ambient conditions until temperature stabilization of the AV600-THT.
- Step 7. Perform a visual and functional test per [Subject].
- Step 8. Document the results.

Table 2: Storage High Temperature One Cycle Profile

Temp [°C]	Time of day
35	01:00
34	02:00
34	03:00
33	04:00
33	05:00
33	06:00
36	07:00
40	08:00
44	09:00
51	10:00

Qualification Test Plan AV600-THT

56	11:00
63	12:00
69	13:00
70	14:00
71	15:00
70	16:00
67	17:00
63	18:00
55	19:00
48	20:00
41	21:00
39	22:00
37	23:00
35	24:00

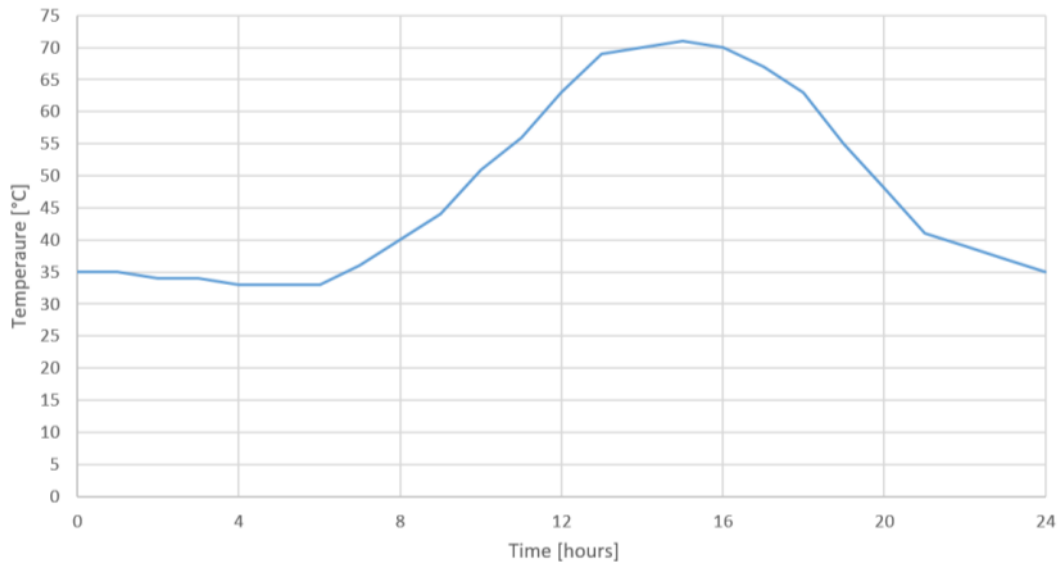

Figure 1: Storage High Temperature One Cycle Profile

Qualification Test Plan AV600-THT

6-2-3 Test Procedure –Operating

- Step 1. At ambient condition perform a visual and functional test per [Subject]
- Step 2. Document the results.
- Step 3. Insert the AV600-THT in the test facility.
- Step 4. Prepare the AV600-THT in its operational configuration.
- Step 5. Locate thermocouples on the AV600-THT.
- Step 6. Turn ON the AV600-THT
- Step 7. .
- Step 8. Expose the AV600-THT to 3 cycles (duration of 24 hours each cycle) of operation high temperature as describe in Table 3.
- Step 9. At the maximum temperature of each one of the 3 cycles, perform functional test per [Subject] as shown
- Step 10. Document the results.
- Step 11. At completion of the test switch OFF the AV600-THT.
- Step 12. Adjust the chamber air temperature to ambient conditions until temperature stabilization of the AV600-THT.
- Step 13. Perform a visual and functional test per [Subject]
- Step 14. Document the results

Table 3: Operation High Temperature One Cycle Profile

Temp [°C]	Time of day
35	1.00
34	2.00
34	3.00
33	4.00
33	5.00
32	6.00
33	7.00
35	8.00
38	9.00
41	10.00
43	11.00
44	12.00
47	13.00
50	14.00
52	15.00
55	16.00
48	17.00

Qualification Test Plan AV600-THT

48	18.00
46	19.00
42	20.00
41	21.00
39	22.00
38	23.00
37	24.00

Figure 2:

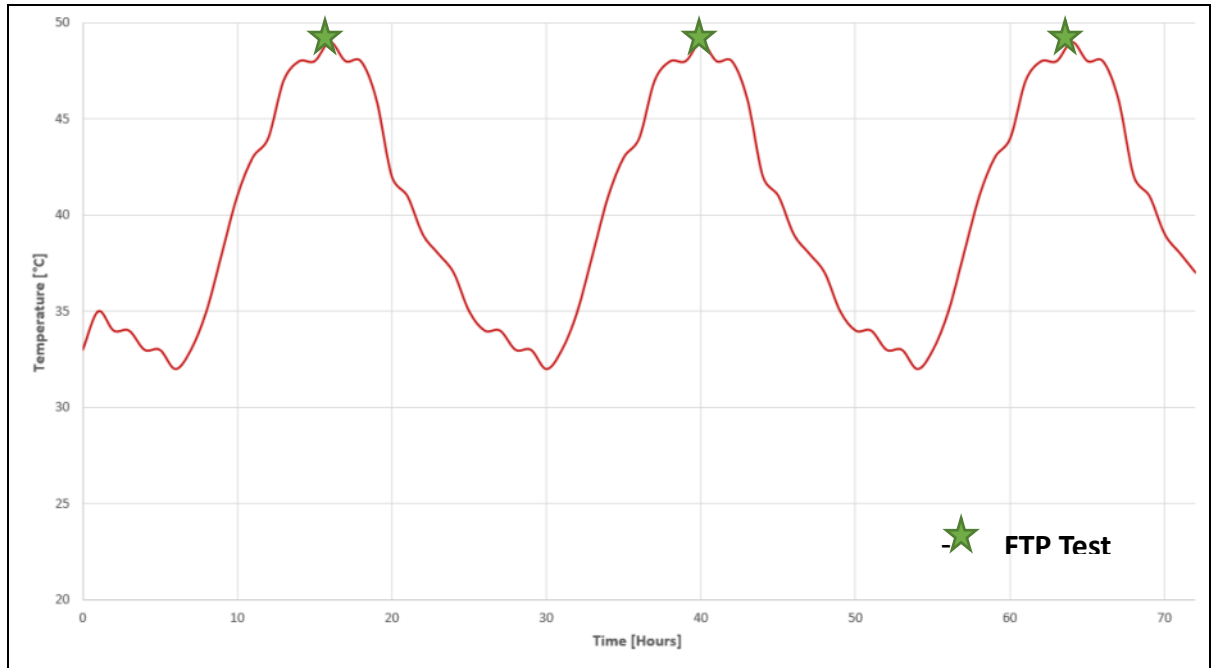

Operation High Temperature Test Profile

6-2-4 Acceptance Criteria

Storage:

Visual- No evidence of damage shall be seen.

Functional -No degradation of performance.

Operation:

Visual- No evidence of damage shall be seen.



Functional -No degradation of performance during exposure to high temperature.

Qualification Test Plan AV600-THT

6-3 LOW TEMPERATURE TEST

6-3-1 Requirements

Perform the low temperature test in accordance with MIL-STD-810G Method 502.5 Procedures I & II with the following parameters:

 Temperature	Storage: -33°C Operation: -20°C
 Cycle Duration	Storage: 72 hours after stabilization Operation: temperature rise time (-33°C~25°C) and should be tested at 0°C and 25°C
 Item condition	Unpacked
> Max. Change Rate	2 °C/min

6-3-2 Test Procedure

- Step 1. At ambient condition perform a visual and functional test per [Subject]
- Step 2. Document the results.
- Step 3. Insert the AV600-THT in the test facility.
- Step 4. Prepare the AV600-THT in its operation configuration.
- Step 5. Locate thermocouples on the AV600-THT.
- Step 6. With the AV600-THT not operating adjust the chamber temperature to -33°C with temperature change rate not exceed of 3°C/min.
- Step 7. After AV600-THT stabilization maintain the chamber temperature at -33°C for dwell duration of 72 hours.
- Step 8. After 4 hours dwell operate the AV600-THT maintain the condition for 2 hours dwell duration.
- Step 9. Perform a functional test per [Subject]. Document the results.
- Step 10. At completion of the test switch OFF the AV600-THT.
- Step 11. Adjust the chamber air temperature to ambient conditions until temperature stabilization of the AV600-THT with temperature change rate not exceed of 3°C/min.
- Step 12. Perform visual and functional tests per [Subject]
- Step 13. Document the results

Qualification Test Plan AV600-THT

3.1.2.3.2. Low Temperature operation

The system shall survive without any damage or degradation of performance during and after exposure to low temperature per MIL-STD-810G/502.5/II.

The minimum steady operational temperature is -20°C with design goal of -33°C according to Figure 2. The system shall be in operational mode during temperature rise time (-33°C to 25°C) and should be tested at 0°C and 25°C

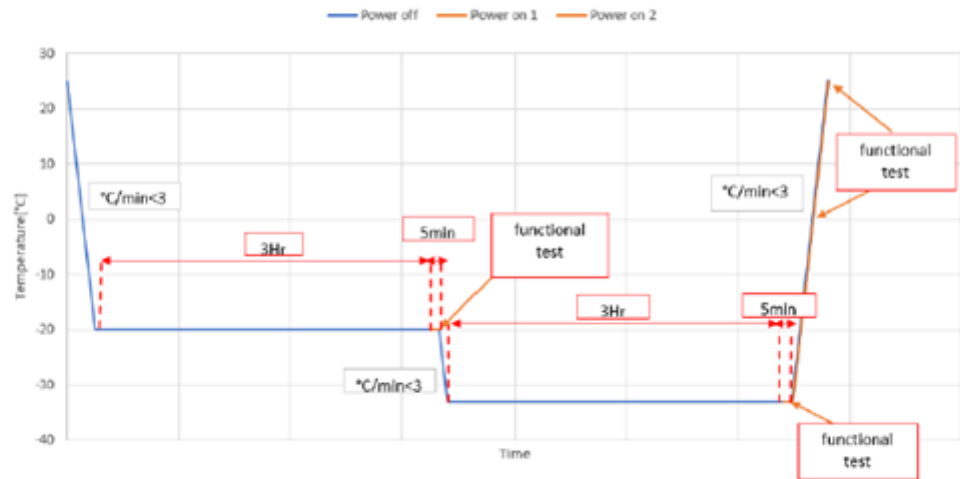

Figure 2: Low Temperature Operational Cycle

6-3-3 Acceptance Criteria

Visual- No evidence of damage shall be seen.





Functional -No degradation of performance.

Qualification Test Plan AV600-THT

6-4 HUMIDITY TEST

6-4-1 Requirements

Perform the humidity test in accordance with MIL-STD-810G Method 507.5 Procedure II Aggravated cycle with the following parameters:

 Temperature	+30°C to +60°C	 Humidity	95±5%RH
Range			
 Cycle Duration	24 hours	 Cycles	10
 Item condition	Unpacked		

6-4-2 Test Procedure

- Step 1. At ambient condition perform a visual and functional test per [Subject]
- Step 2. Document the results.
- Step 3. Insert the AV600-THT in the test facility.
- Step 4. Prepare the AV600-THT in its operation configuration.
- Step 5. With the AV600-THT not operating adjust the chamber temperature with relative humidity of 50±5 %RH, duration of 24 hours.
- Step 6. Adjust the chamber relative humidity to minimum 95%RH, maintain this condition thru the next steps below (steps 7-13).
- Step 7. Reduce the chamber temperature to +30°C.
- Step 8. With duration of 2 hours reduce the chamber temperature to +60°.
- Step 9. Maintain the chamber temperature at +60°C for additional 6 hours.
- Step 10. With duration of 8 hours decrease the chamber temperature to +30°C.
- Step 11. Maintain the chamber temperature at +30°C for additional 8 hours.
- Step 12. Repeat steps 8 thru 11 for a total of 10 cycles.
- Step 13. During the end of the fifth and ten cycles operate the AV600-THT and perform a functional test per [Subject]
- Step 14. Adjust the chamber air temperature to ambient conditions until temperature stabilization of the AV600-THT.
- Step 15. Perform a visual and functional test per [Subject].
- Step 16. Document the results.

Qualification Test Plan AV600-THT

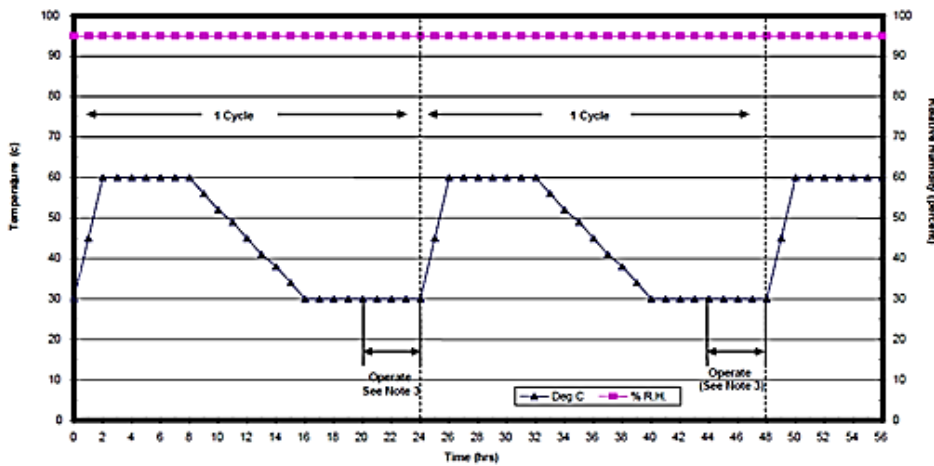

Aggravated temperature-humidity cycle.

NOTES:

1. Maintain the relative humidity at 95 ±4 percent at all times except that during the descending temperature periods the relative humidity may drop to as low as 85 percent.
2. A cycle is 24 hours.
3. Perform operational checks near the end of the fifth and tenth cycles.

Time	Temp.		RH Percent
	°C	°F	
0000	30	86	Constant at 95 percent
0200	60	140	
0800	60	140	
1600	30	86	
2400	30	86	
0200	60	140	
0800	60	140	
1600	30	86	
2400	30	86	

Figure 3: Humidity Test Profile

6-4-3 Acceptance Criteria

Visual- No evidence of damage and corrosion shall be seen.





Functional -No degradation of performance.

Qualification Test Plan AV600-THT

6-5 SALT FOG TEST

6-5-1 Requirements

Perform the salt fog test in accordance with MIL-STD-Method 509.5 with the following parameters:

 Item Condition	Unpacked Non-Operational	 Salt Solution Concentration	5±1%
 Salt Fog PH	6.5 to 7.2	 Salt Fog Fallout Rate	1-3 ml/80cm ² /h
Humidity Condition	95%	Temperature	35°C

6-5-2 Test Procedure

- Step 1. At ambient condition perform a visual and functional test per [Subject]
- Step 2. Document the results.
- Step 3. Install the AV600-THT (mechanical mockup unit is allowed) in the salt fog test chamber with all cables connected. Connector caps may be used instead of the cables.
- Step 4. Adjust the test chamber temperature to +35°C±2°C and condition the AV600-THT for at least two hours before introducing the salt fog.
- Step 5. Expose the AV600-THT to a 5%±1% concentration of salt spray at a temperature of +35°C±2°C for a period of 24 hours.
- Step 6. Remove the AV600-THT from the test chamber and allow it to dry at standard ambient atmosphere for 24 hours. Minimize handling the AV600-THT during the drying period.
- Step 7. Repeat Steps 3 to 6 once again.
- Step 8. Perform a visual and functional test [Subject]
- Step 9. Document the results.

6-5-3 Acceptance Criteria

Visual- No evidence of damage and corrosion shall be seen.



Functional -No degradation of performance.

Qualification Test Plan AV600-THT

6-6 SAND & DUST TEST

6-6-1 Requirements

Perform the Sand & Dust test in accordance with MIL-STD-Method 510.5 with the following parameters:

 Dust particle	< 150um.	 Dust Concentration	10.6 gr/m3
 Wind Speed	8.9 m/s		

6-6-2 Test Procedure

- Step 1. Step 1. At ambient condition perform a visual and functional test per [Subject]
- Step 2. Step 2. Document the results.
- Step 3. Step 3. Insert the AV600-THT in the test facility.
- Step 4. Step 4. Prepare the AV600-THT in its operation configuration.
- Step 5. Step 5. Blowing dust at 25oC for 6 hours, and an additional 6 hours at 49oC (Climatic Category A1)
- Step 6. Step 6. Perform a visual and functional test [Subject]
- Step 7. Step 7. Document the results

6-6-3 Acceptance Criteria

Visual- No evidence of damage and corrosion shall be seen.

Functional -No degradation of performance.

Qualification Test Plan AV600-THT

6-7 IMMERSION TEST

6-7-1 Requirements

Perform the blowing rain test in accordance MIL-STD-810G Method 512.5 Procedure I with the following parameters:

I	Water Depth:	Perform the test according to IP65 requirements.	☒	Item condition	Unpacked Non-Operation
🕒	Duration	2 min			

6-7-2 Test Procedure

- Step 1. At ambient condition conduct a complete visual examination of the test item with special attention to sealed areas, gaskets/seals, and structural integrity, and document the results. Take photographs, if appropriate. Verify that no free water is present; if so, dry.
- Step 2. At ambient condition perform functional test per [Subject]
- Step 3. Weigh the AV600-THT.
- Step 4. Document the results.
- Step 5. Three times immediately before the test, open and close (or remove and replace) any doors, covers, etc., that would be opened during normal use to ensure any seals are functioning properly and are not adhering to the sealing (mating) surfaces.
- Step 6. Ensure temperature differential between the water and the AV600-THT of more than 10°C.
- Step 7. Record the water temperature and the AV600-THT temperature.
- Step 8. Close all sealed areas and valves.
- Step 9. The spraying with a hose on test item in water the surface of the water for duration of 3 minutes.
- Step 10. Remove AV600-THT from the water, wipe the exterior surfaces dry (giving special attention to areas around seals and relief valves), be careful to not allow water to enter the test item while activating the manual valves.
- Step 11. Weigh the AV600-THT.
- Step 12. Open the AV600-THT and examine the interior and contents for evidence of and quantity of any leakage and, if leakage occurred, for probable areas of entry.
- Step 13. Perform functional test per [Subject]
- Step 14. Document the results.

Qualification Test Plan AV600-THT

6-7-3 Acceptance Criteria

Visual

No evidence of water penetration shall be seen inside the AV600X-CH. No evidence of damage shall be seen.

Functional

No degradation of performance.

Qualification Test Plan AV600-THT

6-8 VIBRATION TEST

6-8-1 Requirements

Perform the vibration test in accordance with MIL-STD-810G Method 514.6 category 7. Packaged components by commercial aircraft that it is non-operational in reusable ruggedized packaging -- with the following parameters:

6-8-2 Test Procedure

Test duration: 20 minutes per axis (x,y,z) to simulate 20 landings and takeoffs.

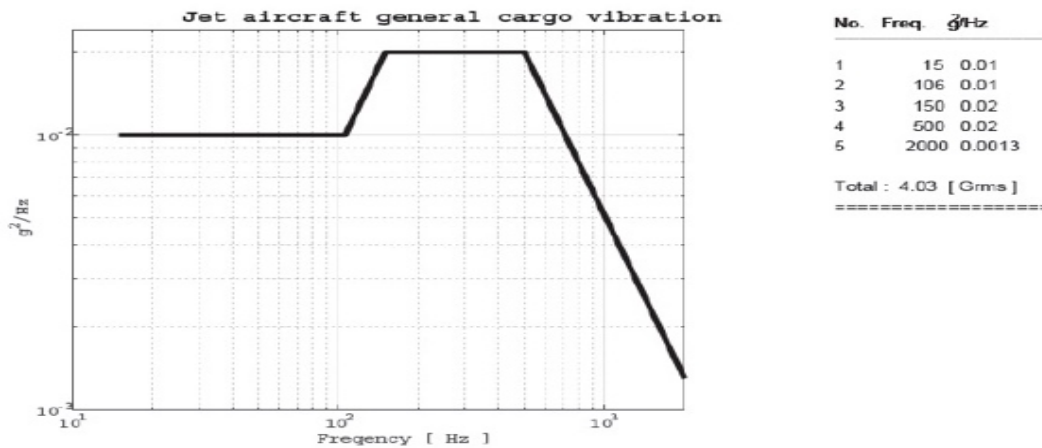

Figure 3: Jet Cargo Aircraft Vibration

6-8-3 Requirements

Perform the vibration test in accordance with MIL-STD-810G Method 514.6 category 7. C-130(J/K) aircraft unpacked and in non-operating mode -- with the following parameters:

6-8-4 Test Procedure

Test duration 400 minutes per axis (x,y,z), simulating 120 flight hours including 20 landings and takeoffs.

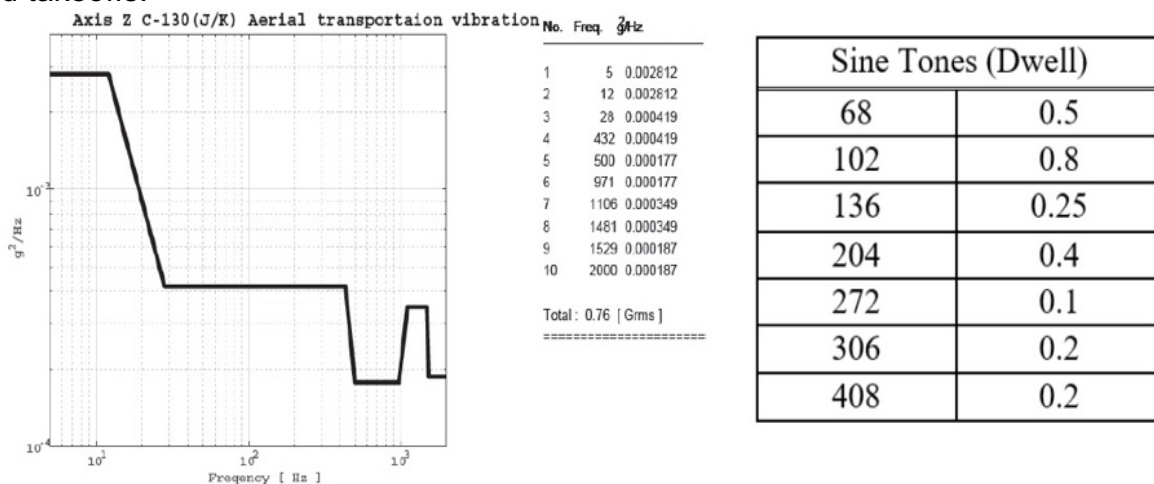

Figure 4: For unknown orientation axis- C-130(J/K) Aerial Transportation Vibration

Qualification Test Plan AV600-THT

6-8-5 Requirements

Perform the vibration test in accordance with MIL-STD-810G Method 514.8 category 4. Ground Transportation (Packaged) – Common Carrier -- with the following parameters:

6-8-6 Test Procedure

Test duration: 190 minutes per axis to simulate 5000 km of driving distance. This test shall be performed using reusable dedicated ruggedized package for spare parts.

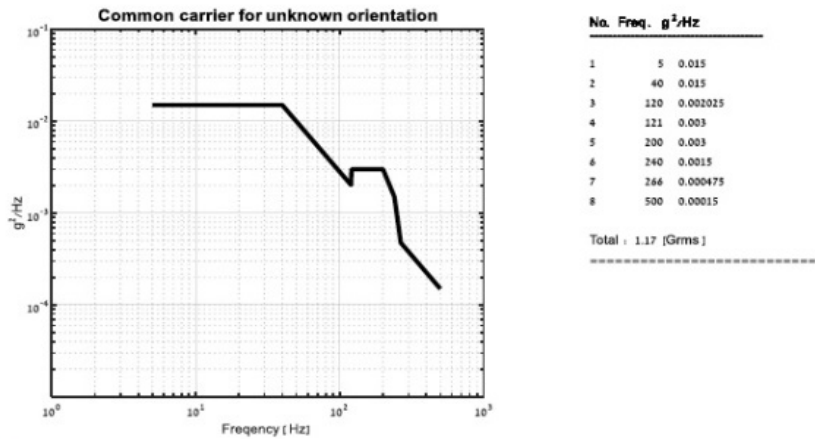

Figure 5: Common Carrier Vibration Profile for unknown orientation

Qualification Test Plan AV600-THT

6-8-7 Requirements

Perform the vibration test in accordance with MIL-STD-810G Method 514.6 category 7. Tactical Transportation – Not Operational – with the following parameters:

6-8-8 Test Procedure

Test duration: 100 minutes per axis to simulate 500,000 km driving distance. Coordinate system according to Figure 1.

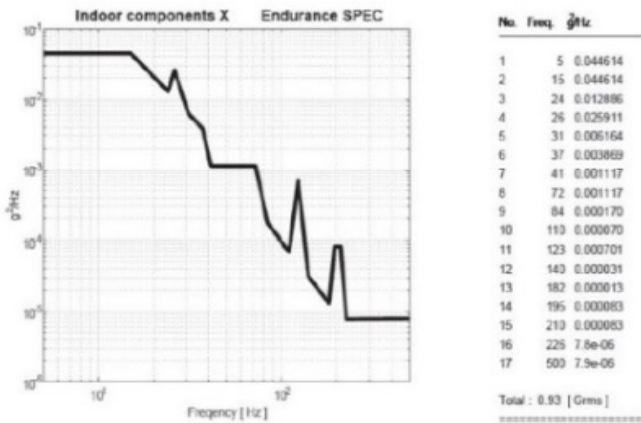

Figure 6: Axis X Tactical Transportation Vibration

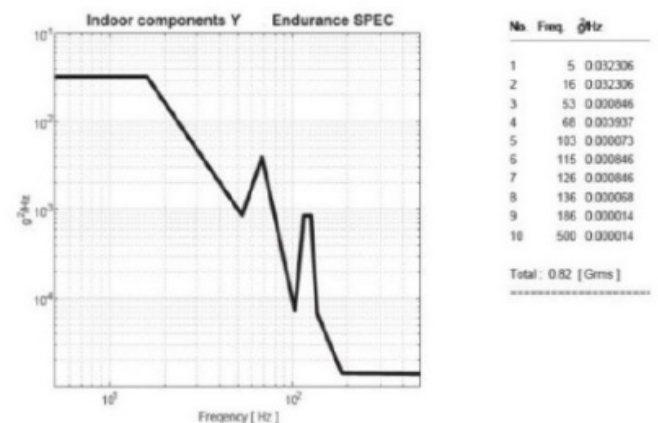

Figure 7: Axis Y Tactical Transportation Vibration

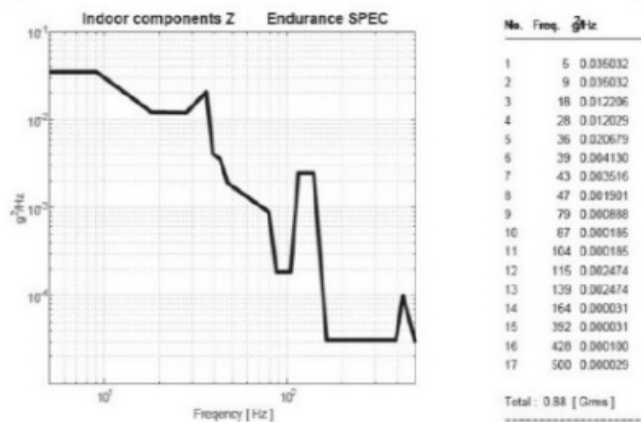

Figure 8: Axis Z Tactical Transportation Vibration

Qualification Test Plan AV600-THT

6-8-9 Requirements

Perform the vibration test in accordance with MIL-STD-810G Method 514.6 category 7. Functional Vibration– with the following parameters:

6-8-10 Test Procedure

Test duration: completion of functional test. Coordinate system according to Figure 1.

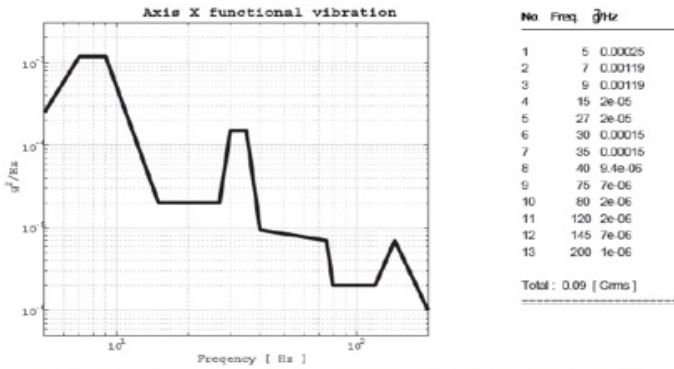

Figure 9: Axis X Tactical Functional Vibration

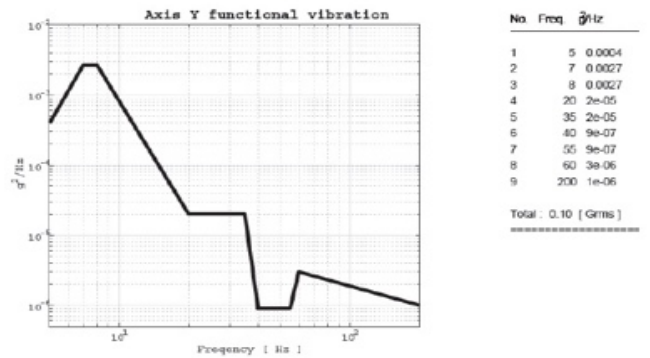

Figure 10: Axis Y Tactical Functional Vibration

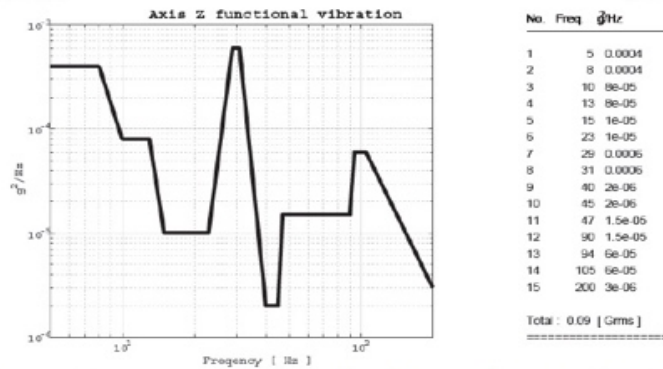

Figure 11: Axis Z Tactical Functional Vibration

6-8-11 Acceptance Criteria

Visual

No evidence of damage and corrosion shall be seen.

Functional

No degradation of performance.

Qualification Test Plan AV600-THT

6-9 SHOCK TEST

6-9-1 Requirements

Perform the Shock test in accordance with MIL-STD-810G Method 516.6. Road Transportation -- with the following parameters:

6-9-2 Test Procedure

Test parameters:

Axis	G peak [g]	Duration [ms]	Pulse	Amount
XYZ	10	11	Sawtooth	3 in each direction (\pm)

6-9-3 Acceptance Criteria

Visual

No evidence of damage and corrosion shall be seen.

Functional





No degradation of performance.

Qualification Test Plan AV600-THT

6-10 TRANSIT DROP TEST

6-10-1 Requirements

Perform the transit drop test in accordance with MIL-STD-810G Method 516.6 Procedure IV with the following parameters:

 Item Condition	Packed	 Height	122 cm
 Total Drops	26	 Impact Surface	Wood

6-10-2 Test Procedure

- Step 1. At ambient condition perform a visual and functional test per [Subject]
- Step 2. Document the results.
- Step 3. Install the AV600-THT in its transit case.
- Step 4. Adjust the drop facility to height of 122 cm.
- Step 5. Assemble the AV600-THT on the drop facility.
- Step 6. Perform 26 drops – one drop on each face, edge and corner.
- Step 7. At completion of the test perform a visual and functional test per [Subject]
- Step 8. Document the results.

6-10-3 Acceptance Criteria

Visual

No evidence of damage shall be seen.

Functional

No degradation of performance.

Qualification Test Plan AV600-THT

6-11 BENCH HANDLING TEST

6-11-1 Requirements

Perform the bench handling test in accordance with MIL-STD-810G Method 516.6 Procedure VI with the following parameters:

⌋ Height	100mm / 45°	☐ Impact Surface	Solid Wood
📦 Item condition	Unpacked – Non-Operation	½ Total Drops	12

6-11-2 Test Procedure

- Step 1. At ambient condition perform a visual and functional test per [Subject]
- Step 2. Document the results.
- Step 3. Configure the item as it would be for servicing – on the base face.
- Step 4. Using one edge as a pivot, lift the opposite edge of the chassis until one of the following conditions occur (whichever occurs first).
- Step 5. The chassis forms an angle of 45° with the horizontal bench top.
- Step 6. The lifted edge of the chassis has been raised 10 cm above the horizontal bench top.
- Step 7. The lifted edge of the chassis is just below the point of perfect balance.
- Step 8. Let the chassis drop back freely to the horizontal bench top. Repeat, using other practical edges of the same horizontal face as pivot points, for a total of four drops.
- Step 9. Repeat step 2 thru step 3 with the AV600-THT resting on 2 other side faces (Flat faces, without connectors) until it has been dropped for a total of four times on each face. The AV600-THT shall not be operating.
- Step 10. Perform a visual and functional test per [Subject]
- Step 11.** Document the results.

6-11-3 Acceptance Criteria

Visual

No evidence of damage shall be seen.

Functional

No degradation of performance.

Qualification Test Plan AV600-THT

7 MIL-STD-461F REQUIREMENTS FOR THE CONTROL OF ELECTROMAGNETIC INTERFERENCE CHARACTERISTICS OF SUBSYSTEMS AND EQUIPMENT

The AV600-THT shall be tested under the ELECTROMAGNETIC INTERFERENCE CHARACTERISTICS as defined by MIL-STD-461F, as detailed in Table 1

Table 4: List of Tests

#	Test	
		Spec' as Equipment Conditions
1	CE102	Conducted emissions, power leads, 10KHz to 10MHz
2	CS101	Conducted susceptibility, power leads, 30Hz to 150KHz
3	CS114	Conducted susceptibility, bulk cable injection, 10KHz to 200MHz, curves 3&4
4	CS115	Conducted susceptibility, bulk cable injection, impulse excitation
5	CS116	Conducted susceptibility, damped sinusoidal transients, cables and power leads, 10KHz to 100MHz
6	RE102	Radiated emissions, electric filed, 10KHz to 18GHz
7	RS103	Radiated susceptibility, electric filed, 2Mhz to 18GHz, 50V/m

Qualification Test Plan AV600-THT

RE102 TEST Requirements Perform the Radiated emissions, electric field test in accordance with MIL-STD-461F the following parameters: **10KHz to 18GHz**

7-1-1 Test Procedure

Limit

Electric field emissions shall not be radiated in excess of those shown in Figures RE102-1 through RE102-4. Above 30 MHz, the limits shall be met for both horizontally and vertically polarized fields.

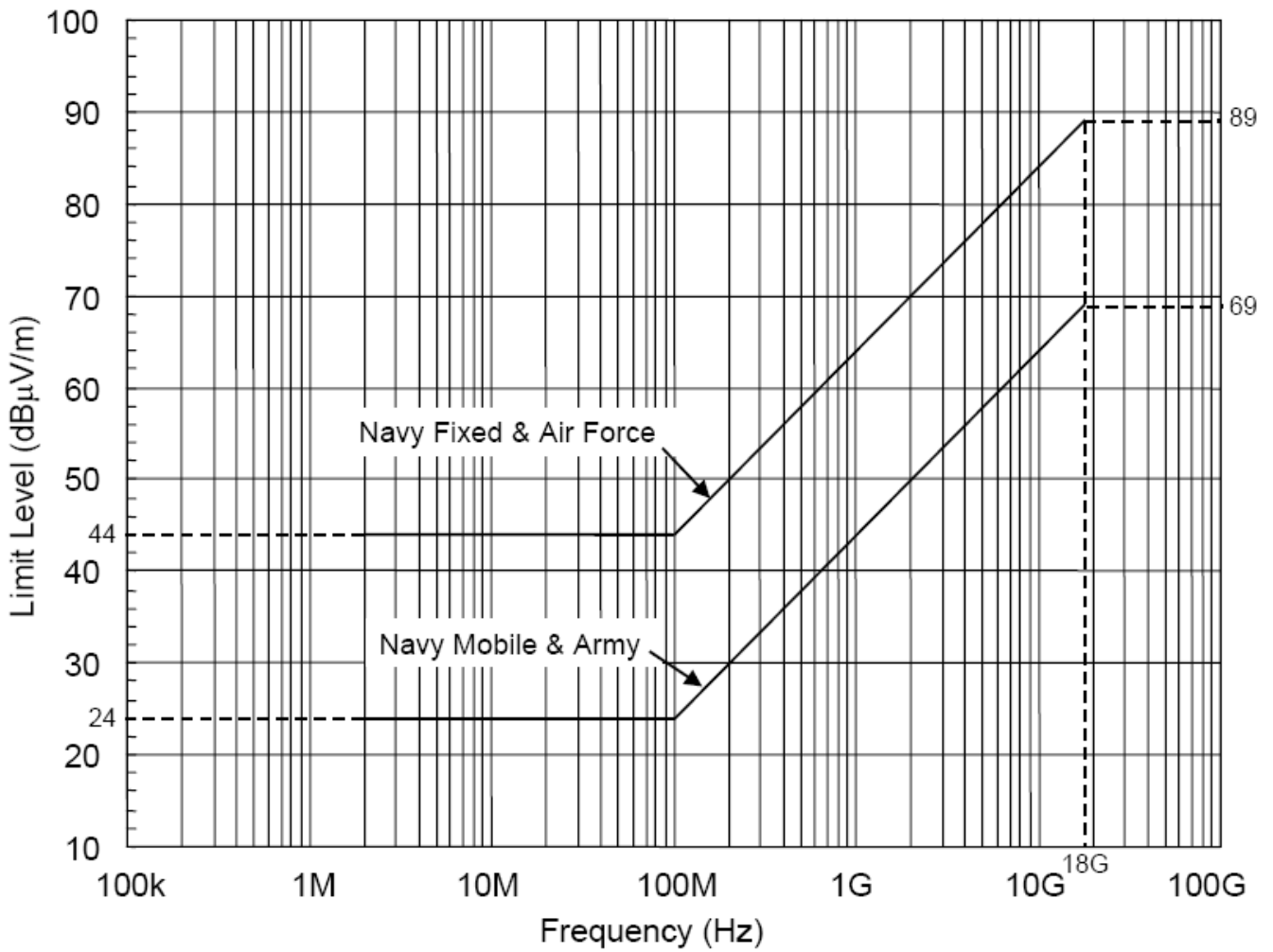
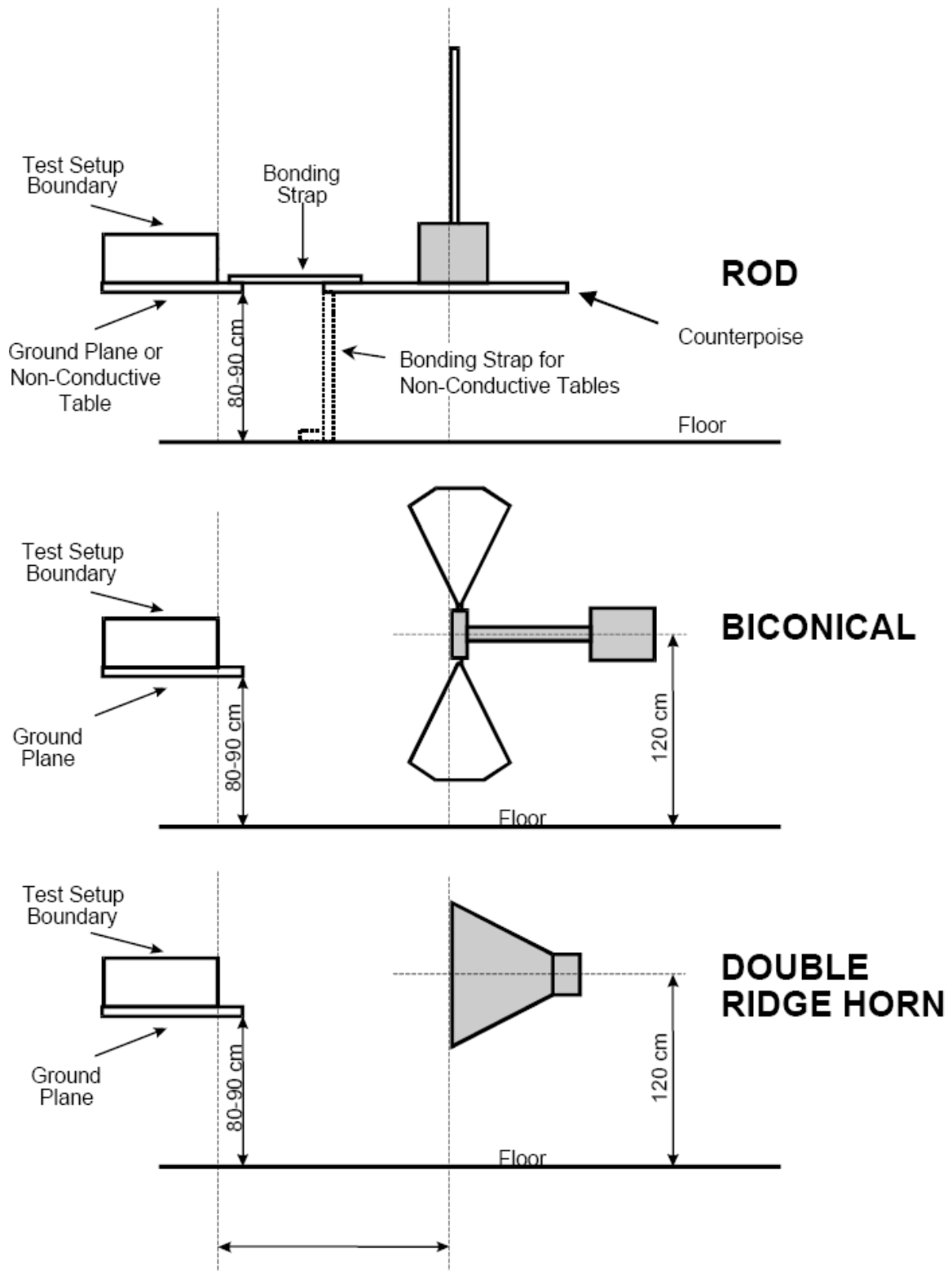

FIGURE RE102-4. RE102 limit for ground applications.

Qualification Test Plan AV600-THT

7-1-2 Test Configuration



Qualification Test Plan AV600-THT

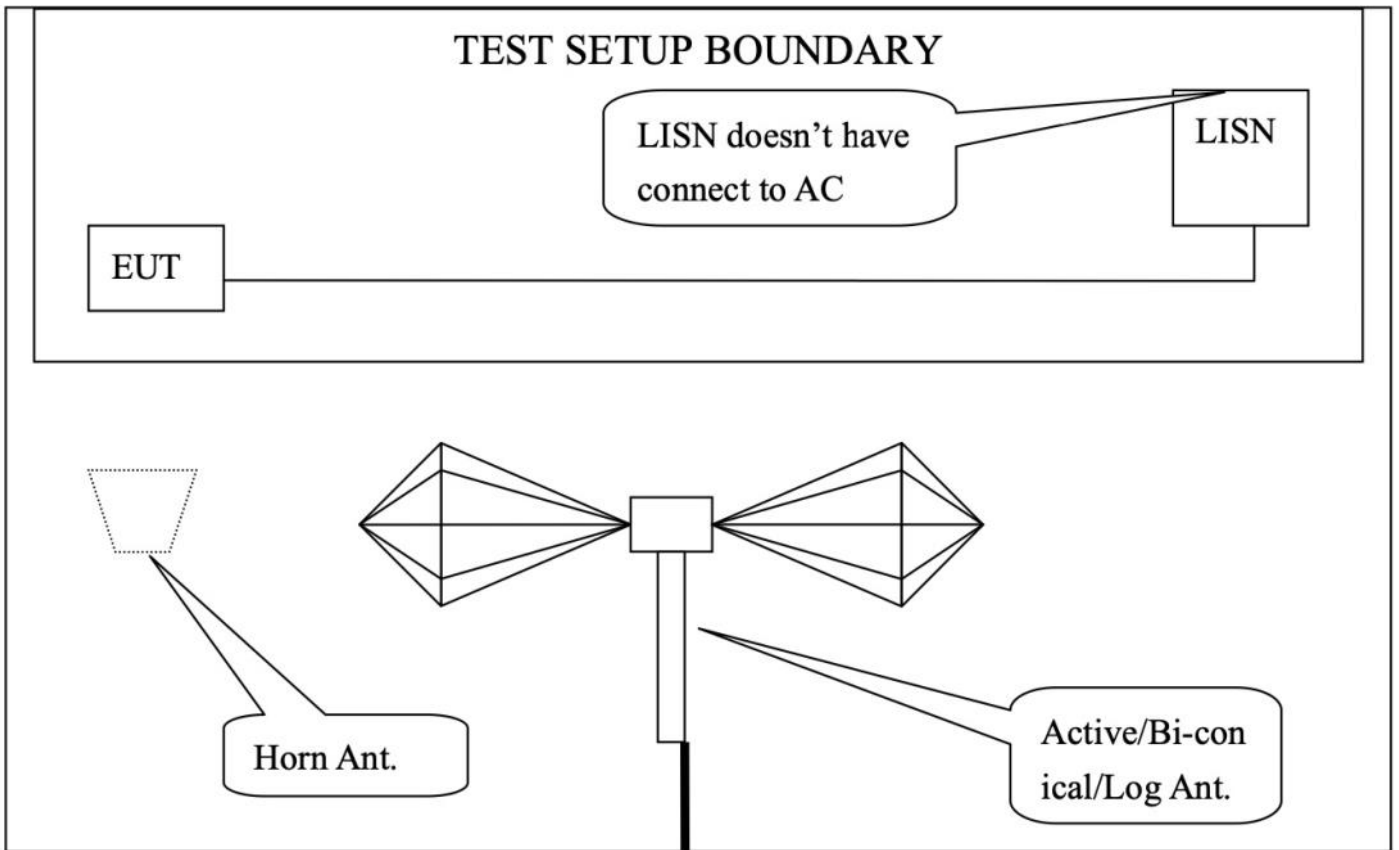

Qualification Test Plan AV600-THT

7-2 CE102 TEST

7-2-1 Requirements

Perform the Conducted emissions, power leads test in accordance with MIL-STD-461F the following parameters: **10KHz to 10MHz**

7-2-2 Test Procedure

Conducted emissions on power leads shall not exceed the applicable values shown on Figure CE102-1.

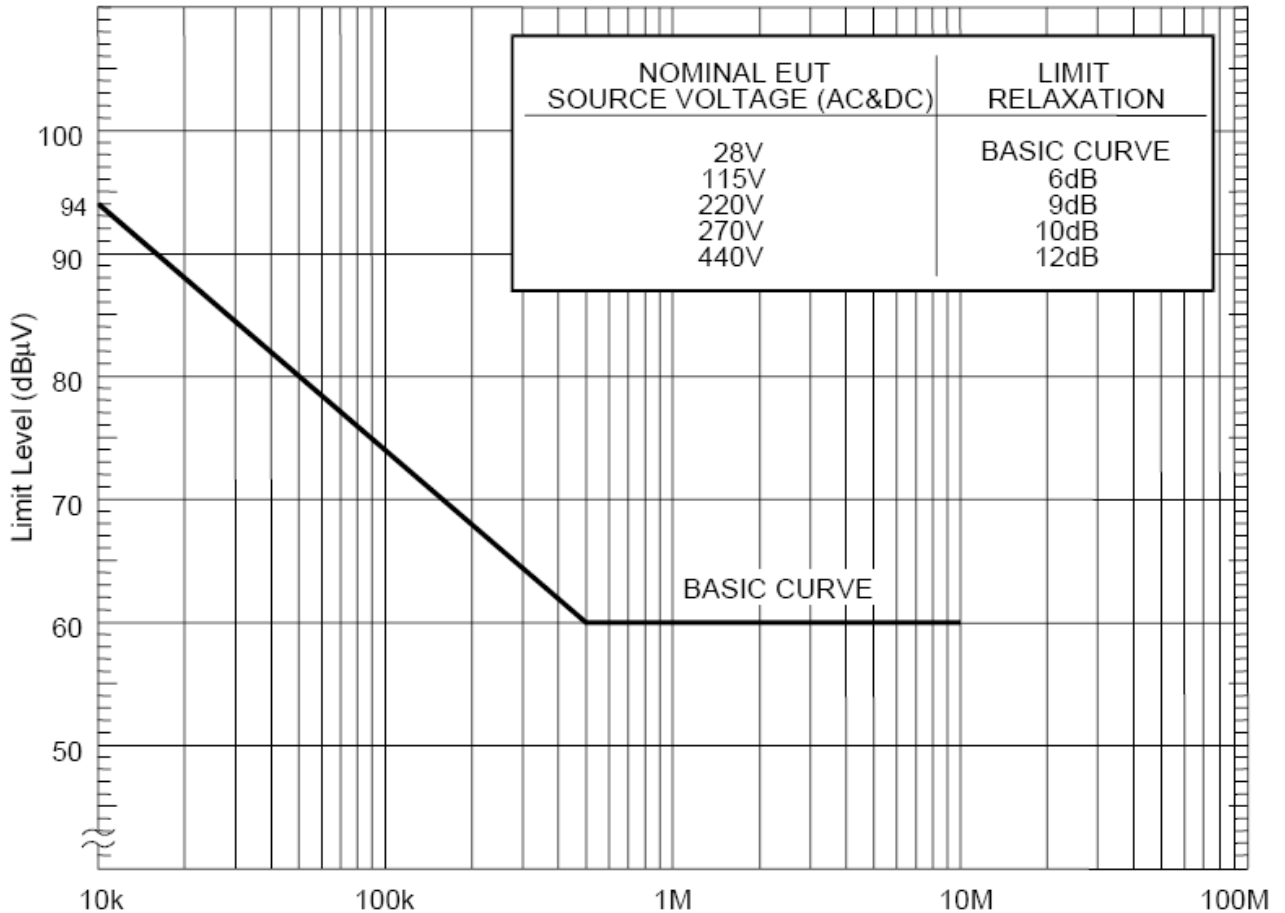

The magnetic emission of EUT representative of its type shall be tested by the method(s) according to MIL STD 461E/F.

Qualification Test Plan AV600-THT

7-2-3 Test Configuration

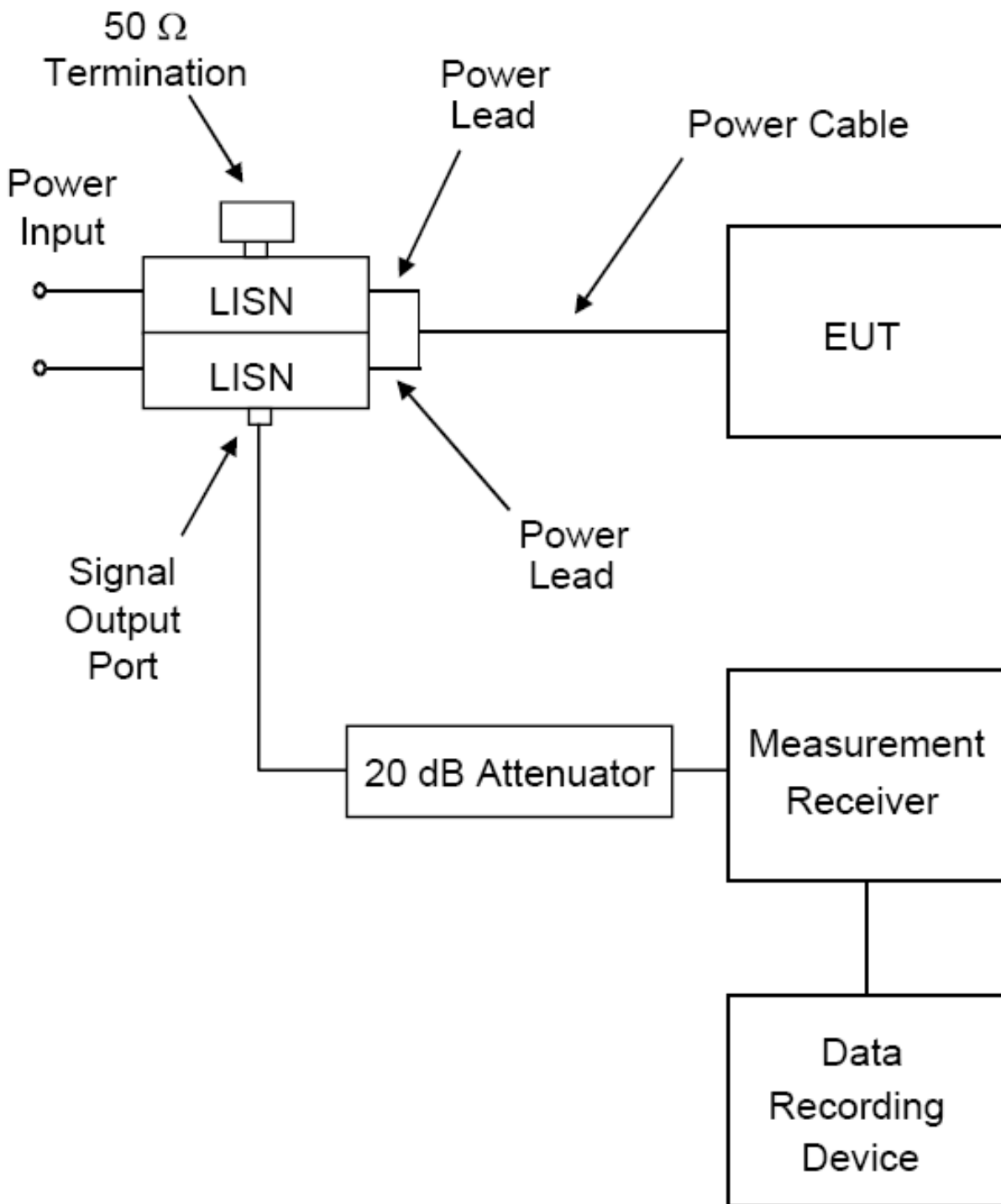

Conducted emissions on power leads shall not exceed the applicable values shown on Figure CE102-1.

Qualification Test Plan AV600-THT

7-3 CS101 TEST

7-3-1 Requirements

Perform the Conducted susceptibility, power leads test in accordance with MIL-STD-461F the following parameters: **30Hz to 150KHz**

7-3-2 Test Procedure

Limit

The EUT shall not exhibit any malfunction, degradation of performance, or deviation from specified indications, beyond the tolerances indicated in the individual equipment or subsystem specification, when subjected to a test signal with voltage levels as specified in

Figure CS101-1.

The requirement is also met when the power source is adjusted to dissipate the power level

shown in Figure CS101-2 in a 0.5 ohm load and the EUT is not susceptible.

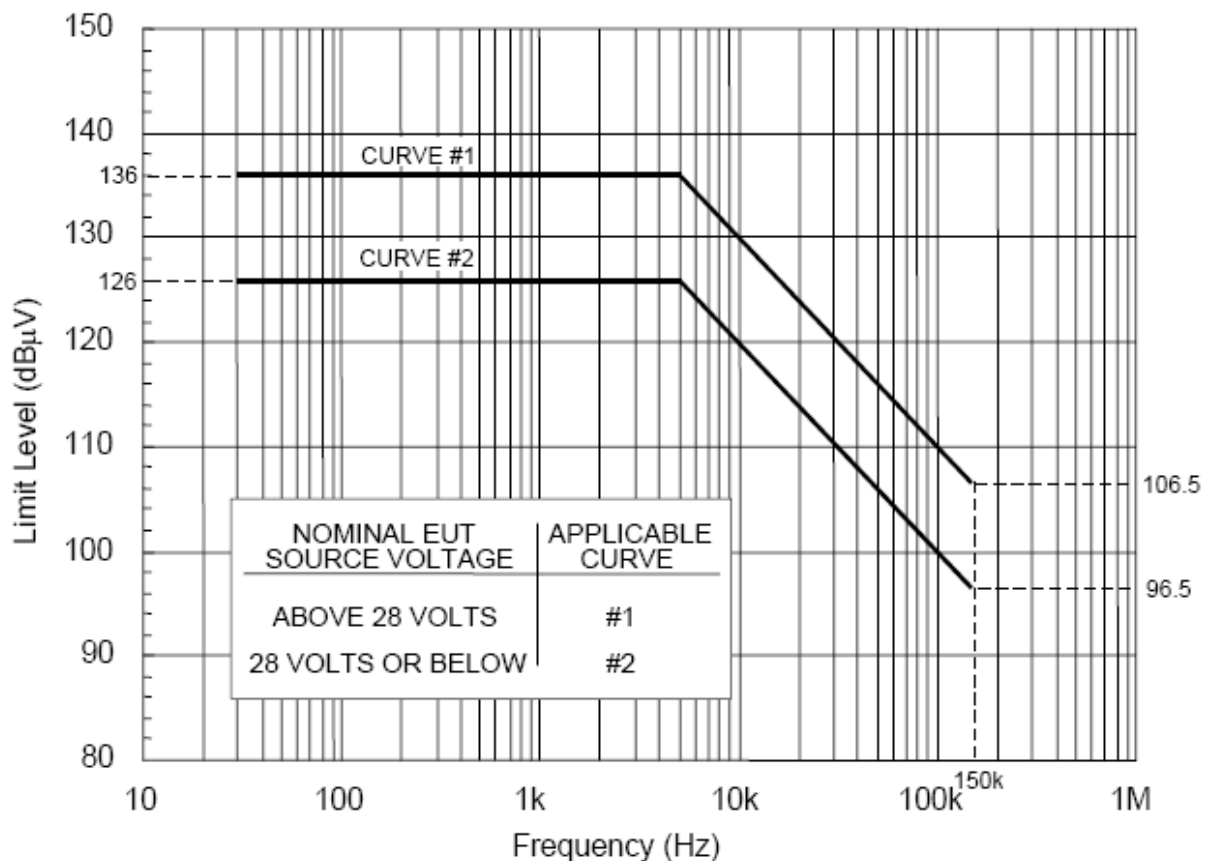

FIGURE CS101-1. CS101 voltage limit for all applications.

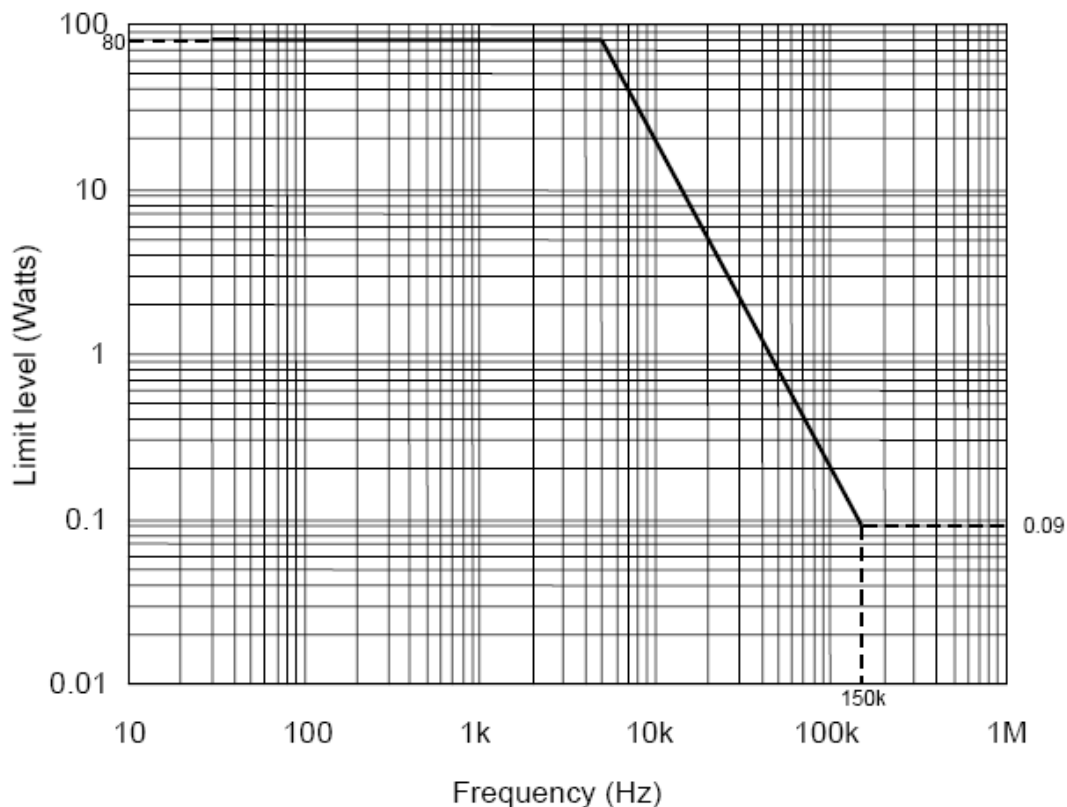

FIGURE CS101-2. CS101 power limit for all applications.

Classification Of Functional Status

All classifications are for the total device/system functional status.

Class A: all functions of a device/system perform as designed during and after exposure to disturbance.

Class B: all functions of a device/system perform as designed during exposure. However, one or more of them can go beyond specified tolerance. All functions return automatically to within normal limits after exposure is removed.

Class C: one or more functions of a device/system do not perform as designed during exposure but return automatically to normal operation after exposure is removed.

Class D: one or more functions of a device/system do not perform as designed during exposure and do not return to normal operation until exposure is removed and the device/system is reset by simple “operator/use” action.

Class E: one or more functions of a device/system do not perform as designed during and after exposure and cannot be returned to proper operation without repairing or replacing the device/system.

7-3-3 Test Configuration

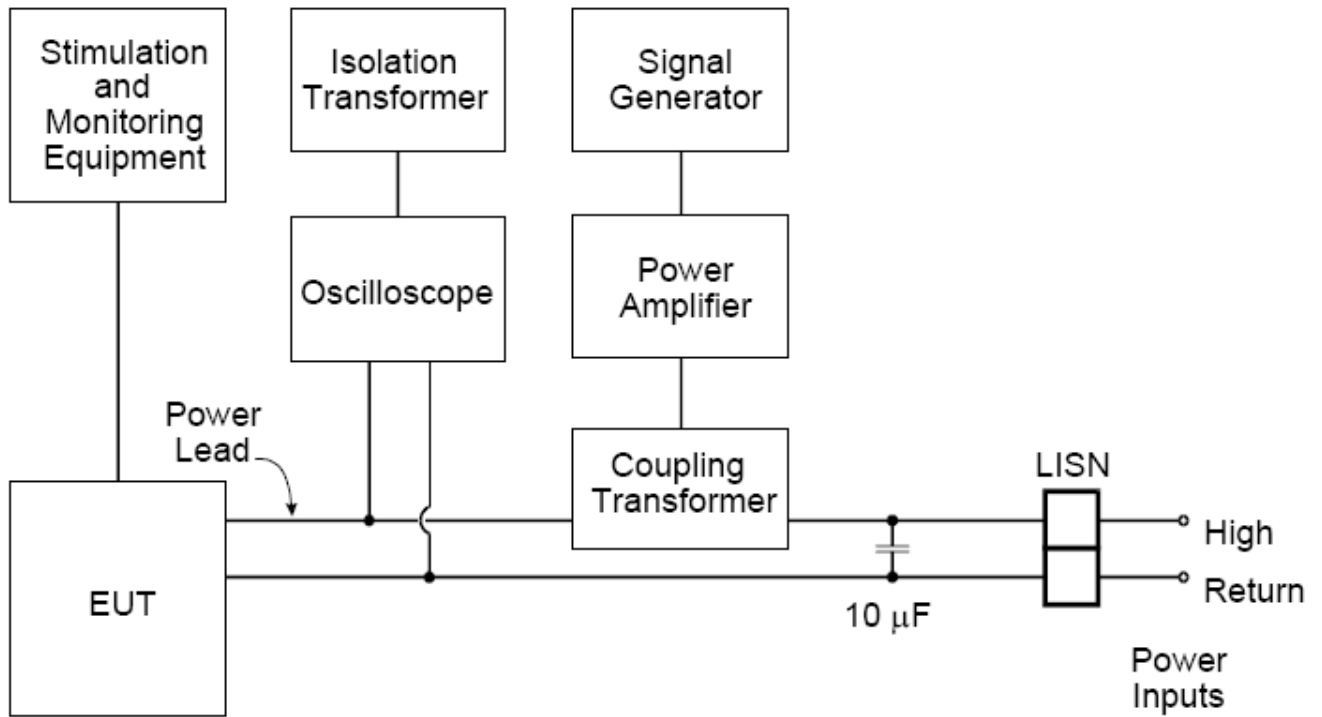

FIGURE CS101-4. Signal injection, DC or single phase AC

Qualification Test Plan AV600-THT

7-4 CS114 TEST

7-4-1 Requirements

Perform the Conducted susceptibility, bulk cable injection test in accordance with MIL-STD-461F the following parameters: **10KHz to 200MHz, curves 3&4**

Limit

The EUT shall not exhibit any malfunction, degradation of performance, or deviation from specified indications, beyond the tolerances indicated in the individual equipment or subsystem

specification, when subjected to a test signal with voltage levels as specified in Figure CS114.

The requirement is also met when the power source is adjusted to dissipate the power level

shown in Figure CS114 and the EUT is not susceptible.

7-4-2 Test Procedure

The CS114 test is used to verify the ability of the EUT to withstand RF signals coupled onto EUT associated cabling

Frequency Range: 10KHz (4 KHz) – 200MHz

Dwell Time: The greater of 3 seconds or EUT response time per frequency

Frequency Step: max 5% (4KHz-1MHz), max 1% (1MHz-30MHz), max 0.1% (30MHz-200MHz)

Unit: Current (dBuA)

Modulation: 1KHz, 50% Duty Cycle, Pulse Modulation

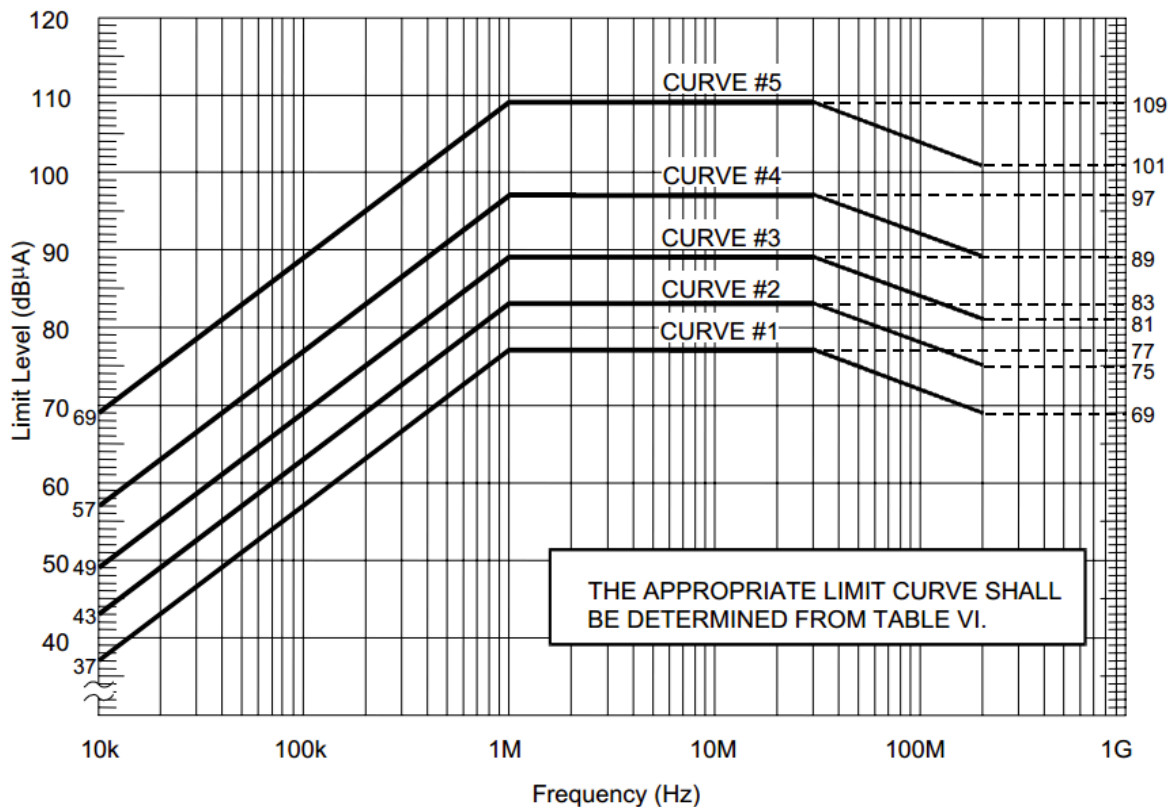

Classification Of Functional Status

All classifications are for the total device/system functional status.

Class A: all functions of a device/system perform as designed during and after exposure to disturbance.

Class B: all functions of a device/system perform as designed during exposure. However, one or more of them can go beyond specified tolerance. All functions return automatically to within normal limits after exposure is removed.

Class C: one or more functions of a device/system do not perform as designed during exposure but return automatically to normal operation after exposure is removed.

Class D: one or more functions of a device/system do not perform as designed during exposure and do not return to normal operation until exposure is removed and the device/system is reset by simple “operator/use” action.

Class E: one or more functions of a device/system do not perform as designed during and after exposure and cannot be returned to proper operation without repairing or replacing the device/system.

7-4-3 Test Configuration

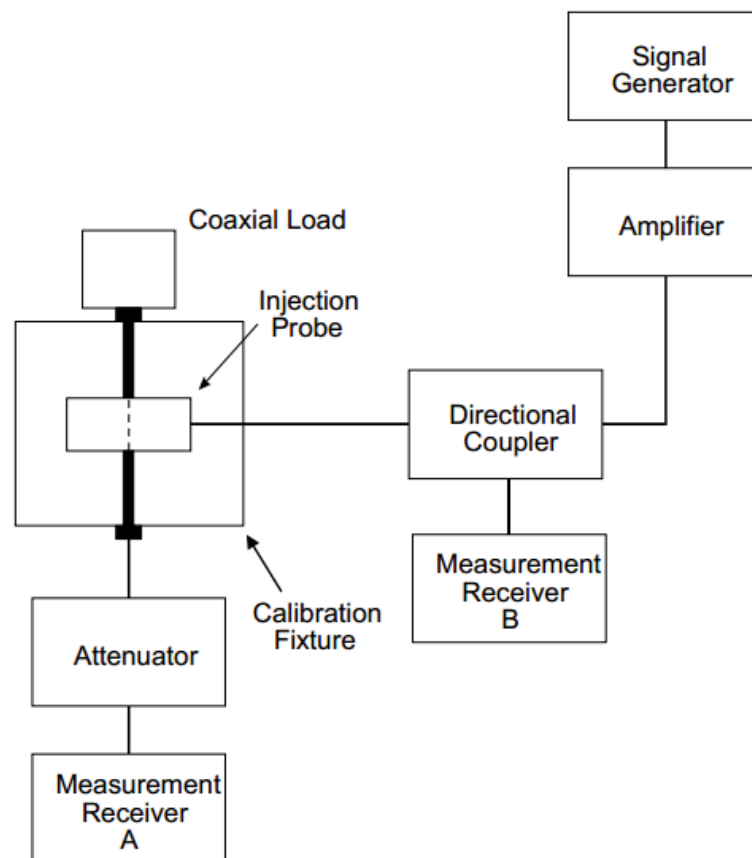

Qualification Test Plan AV600-THT

7-5 CS115 TEST

7-5-1 Requirements

Perform the Conducted susceptibility, bulk cable injection test in accordance with MIL-STD-461F the following parameters: **impulse excitation**

Limit

The EUT shall not exhibit any malfunction, degradation of performance, or deviation from specified indications, beyond the tolerances indicated in the individual equipment or subsystem specification, when subjected to a test signal with voltage levels as specified in Figure CS115.

The requirement is also met when the power source is adjusted to dissipate the power level shown in Figure CS115 and the EUT is not susceptible.

7-5-2 Test Procedure

The CS115 test is used to verify the ability of the EUT to withstand impulse signals coupled onto EUT associated cabling

Frequency Range: Broadband

Unit: Current (A)

Signal: Impulse

Test duration: 1 minute per application

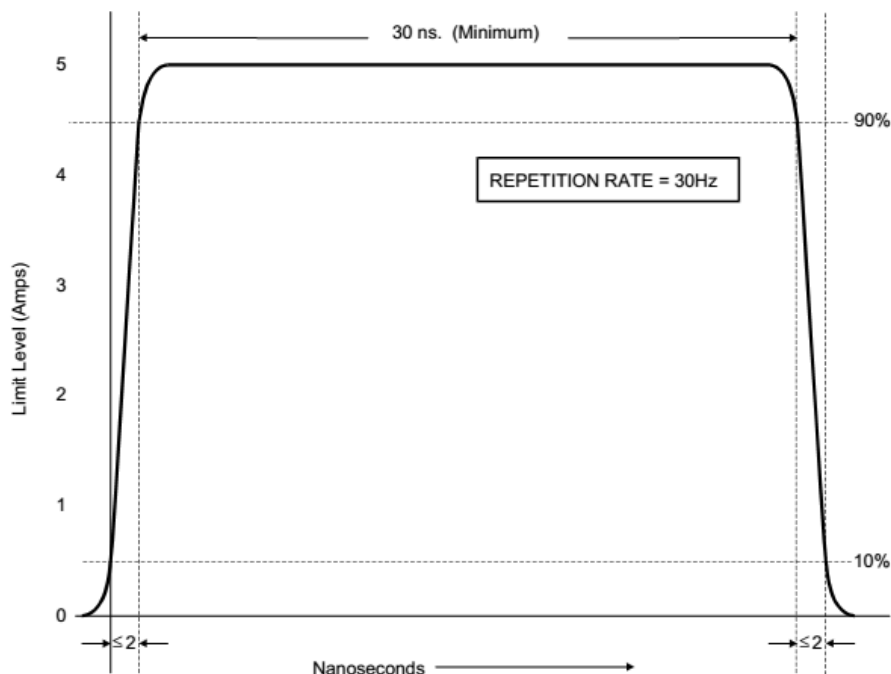

Qualification Test Plan AV600-THT

Classification Of Functional Status

All classifications are for the total device/system functional status.

Class A: all functions of a device/system perform as designed during and after exposure to disturbance.

Class B: all functions of a device/system perform as designed during exposure.

However, one or more of them can go beyond specified tolerance. All functions return automatically to within normal limits after exposure is removed.

Class C: one or more functions of a device/system do not perform as designed during exposure but return automatically to normal operation after exposure is removed.

Class D: one or more functions of a device/system do not perform as designed during exposure and do not return to normal operation until exposure is removed and the device/system is reset by simple “operator/use” action.

Class E: one or more functions of a device/system do not perform as designed during and after exposure and cannot be returned to proper operation without repairing or replacing the device/system.

7-5-3 Test Configuration

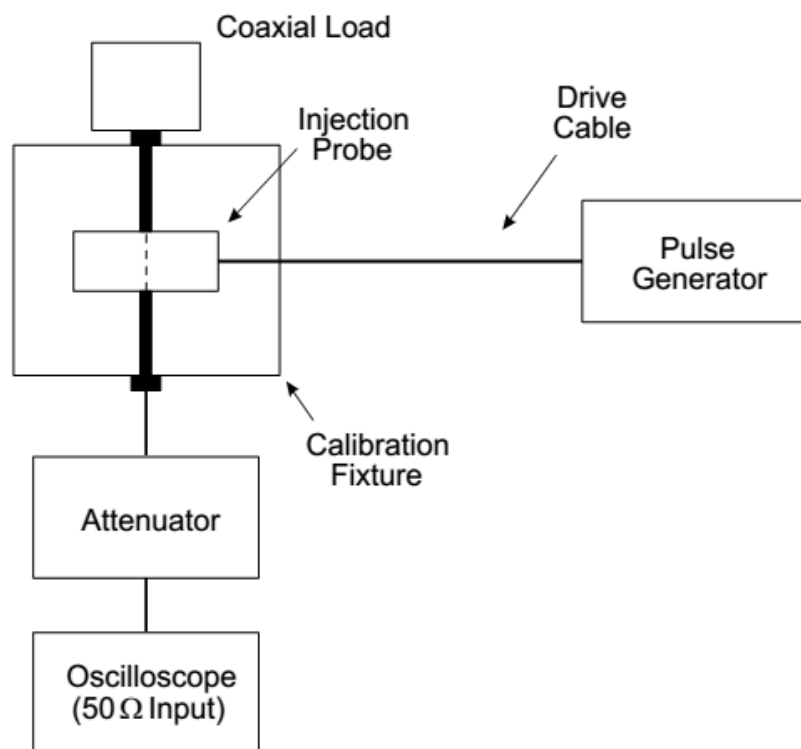

Qualification Test Plan AV600-THT

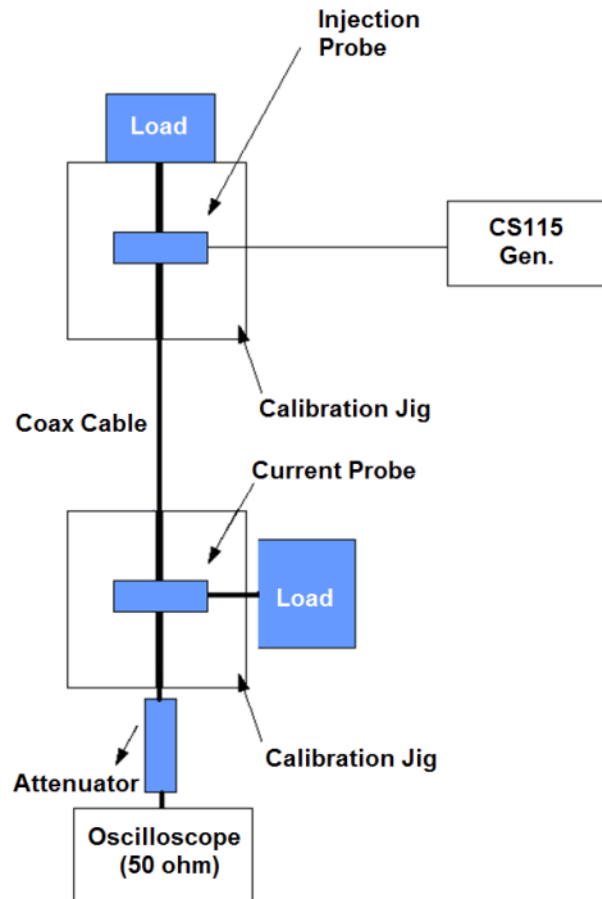

Qualification Test Plan AV600-THT

7-6 CS116 TEST

7-6-1 Requirements

Perform the Conducted susceptibility, damped sinusoidal transients, cables and power leads test in accordance with MIL-STD-461F the following parameters: **10KHz to 100MHz**

Limit

The EUT shall not exhibit any malfunction, degradation of performance, or deviation from specified indications, beyond the tolerances indicated in the individual equipment or subsystem specification, when subjected to a test signal with voltage levels as specified in Figure CS116.

The requirement is also met when the power source is adjusted to dissipate the power level shown in Figure CS116 and the EUT is not susceptible.

7-6-2 Test Procedure

The CS116 test is used to verify the ability of the EUT to withstand damped sinusoidal transients coupled onto EUT associated cables and power leads.

Frequency Range: 10KHz-100MHz

Unit: Current (A)

Interference Signal: Damped Sinusoidal Transients

Test Duration: 5 minutes per application

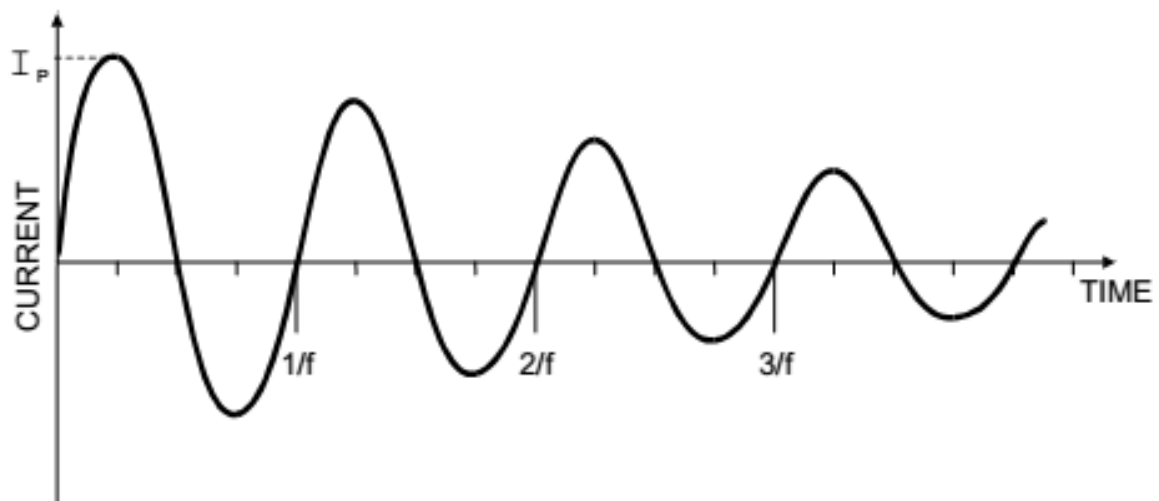

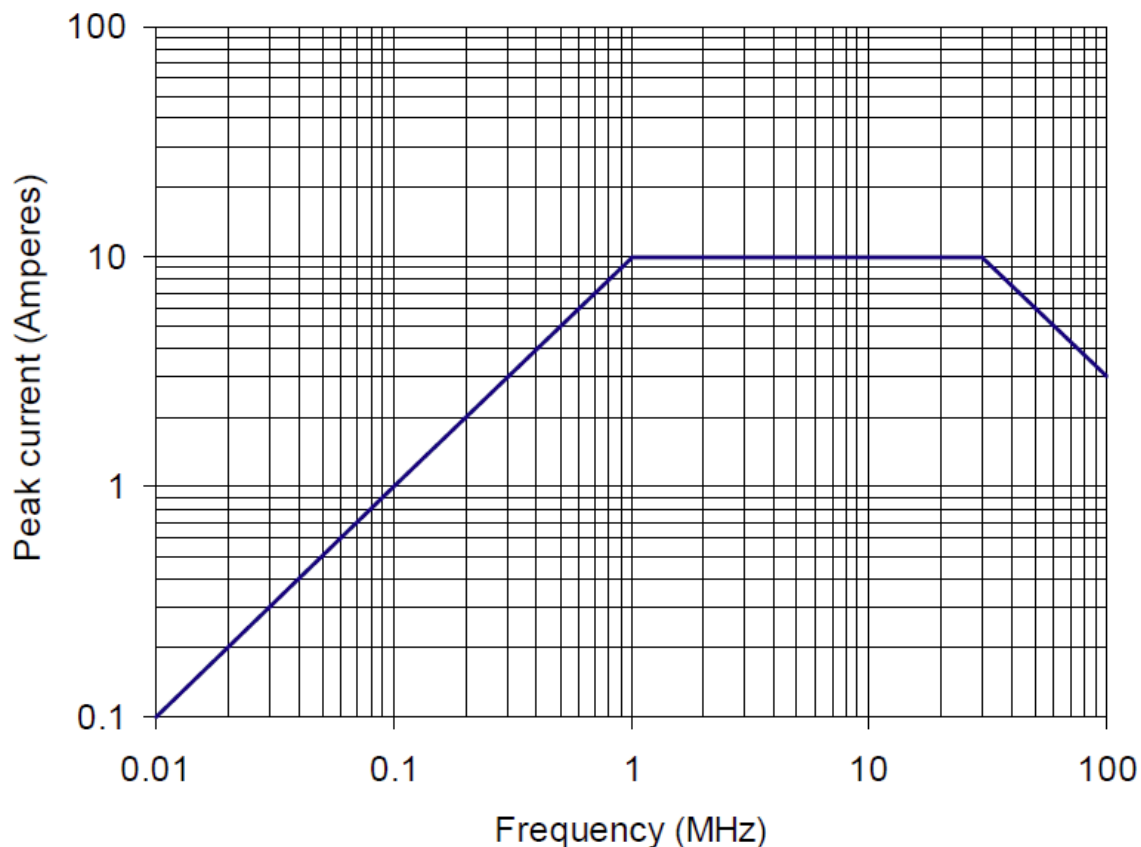

Test Frequencies: 10 kHz, 100 kHz, 1 MHz, 10 MHz, 30 MHz, 100 MHz as a minimum

Classification Of Functional Status

All classifications are for the total device/system functional status.

Class A: all functions of a device/system perform as designed during and after exposure to disturbance.

Class B: all functions of a device/system perform as designed during exposure. However, one or more of them can go beyond specified tolerance. All functions return automatically to within normal limits after exposure is removed.

Class C: one or more functions of a device/system do not perform as designed during exposure but return automatically to normal operation after exposure is removed.

Class D: one or more functions of a device/system do not perform as designed during exposure and do not return to normal operation until exposure is removed and the device/system is reset by simple "operator/use" action.

Class E: one or more functions of a device/system do not perform as designed during and after exposure and cannot be returned to proper operation without repairing or replacing the device/system.

Qualification Test Plan AV600-THT

7-6-3 Test Configuration

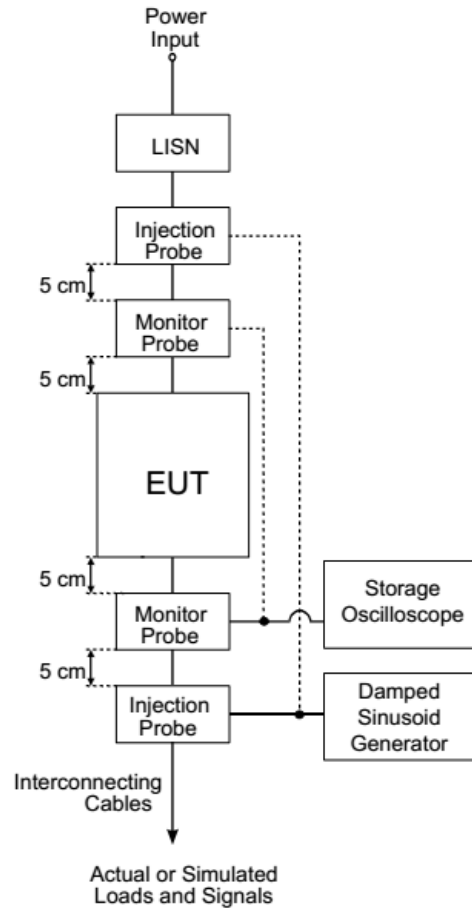

Tested port	Polarity	Frequency (MHz)	Pulse Level (A)	Injected Current Level (A)
Shielded Power Cable	Positive	0,01	0,1	35,3
	Positive	0,1	1	32,2
	Positive	1	10	53,3
	Positive	10	10	5,7
	Positive	30	10	6,7
	Positive	100	3	2,1
	Negative	0,01	0,1	35,8
	Negative	0,1	1	32,6
	Negative	1	10	53,8
	Negative	10	10	5,8
	Negative	30	10	6,6
	Negative	100	3	2,0

Qualification Test Plan AV600-THT

7-7 RS103 TEST

7-7-1 Requirements

Perform the Radiated susceptibility, electric field test in accordance with MIL-STD-461F the following parameters: **2MHz to 18GHz, 50V/m**

7-7-2 Test Procedure

Limit

The EUT shall not exhibit any malfunction, degradation of performance, or deviation from specified indications, beyond the tolerances indicated in the individual equipment or subsystem specification, when subjected to the radiated electric fields listed in Table VII and modulated as specified below. Up to 30 MHz, the requirement shall be met for vertically polarized fields. Above 30 MHz, the requirement shall be met for both horizontally and vertically polarized fields. Circular polarized fields are not acceptable.

PLATFORM FREQ. RANGE		LIMIT LEVEL (VOLTS/METER)							
		AIRCRAFT (EXTERNAL OR SAFETY CRITICAL)	AIRCRAFT INTERNAL	ALL SHIPS (ABOVE DECKS) AND SUBMARINES (EXTERNAL)*	SHIPS (METALLIC) (BELOW DECKS)	SHIPS (NON-METALLIC) (BELOW DECKS)	SUBMARINES (INTERNAL)	GROUND	SPACE
2 MHz ↓ 30 MHz	A	200	200	200	10	50	5	50	20
	N	200	200	200	10	50	5	10	20
	AF	200	20	-	-	-	-	10	20
30 MHz ↓ 1 GHz	A	200	200	200	10	10	10	50	20
	N	200	200	200	10	10	10	10	20
	AF	200	20	-	-	-	-	10	20
1 GHz ↓ 18 GHz	A	200	200	200	10	10	10	50	20
	N	200	200	200	10	10	10	50	20
	AF	200	60	-	-	-	-	50	20
18 GHz ↓ 40 GHz	A	200	200	200	10	10	10	50	20
	N	200	60	200	10	10	10	50	20
	AF	200	60	-	-	-	-	50	20

KEY: A = Army
N = Navy
AF = Air Force

* For equipment located external to the pressure hull of a submarine but within the superstructure, use SHIPS (METALLIC)(BELOW DECKS)

Classification Of Functional Status

All classifications are for the total device/system functional status.

Class A: all functions of a device/system perform as designed during and after exposure to disturbance.

Qualification Test Plan AV600-THT

Class B: all functions of a device/system perform as designed during exposure.

However, one or more of them can go beyond specified tolerance. All functions return automatically to within normal limits after exposure is removed.

Class C: one or more functions of a device/system do not perform as designed during exposure but return automatically to normal operation after exposure is removed.

Class D: one or more functions of a device/system do not perform as designed during exposure and do not return to normal operation until exposure is removed and the device/system is reset by simple “operator/use” action.

Class E: one or more functions of a device/system do not perform as designed during and after exposure and cannot be returned to proper operation without repairing or replacing the device/system.

7-7-3 Test Configuration

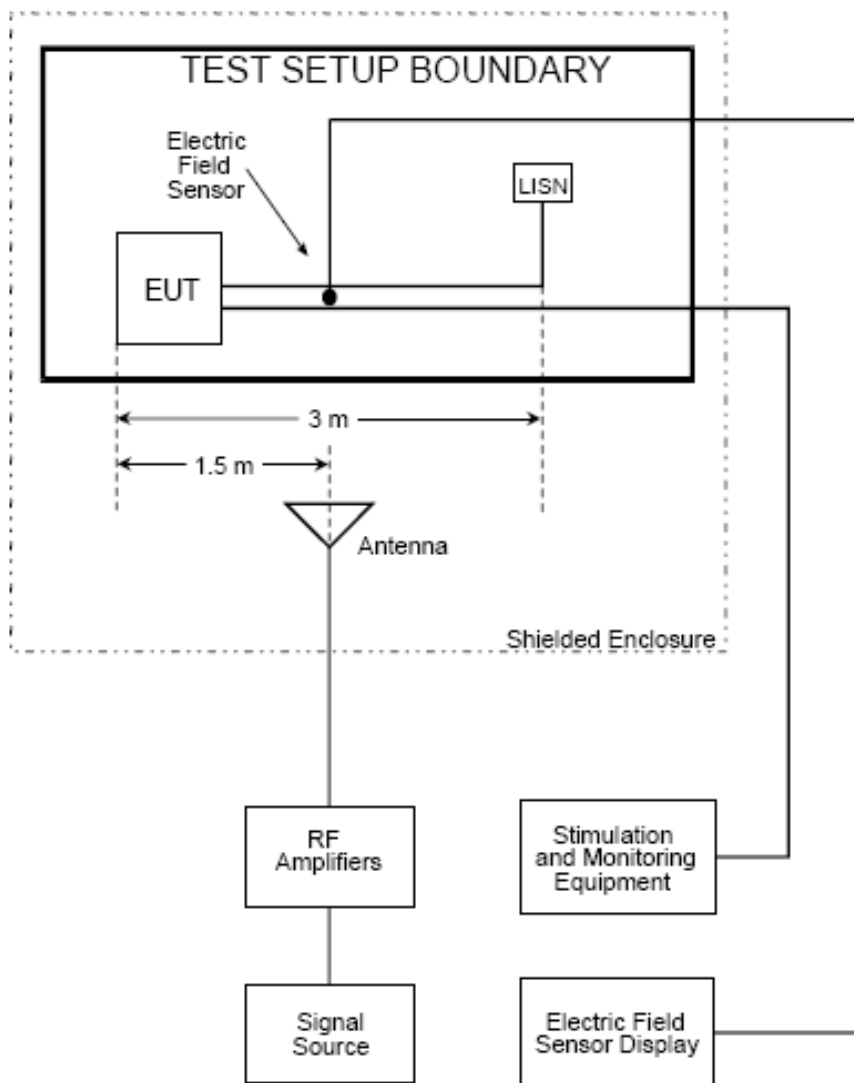

FIGURE RS103-1. Test equipment configuration.

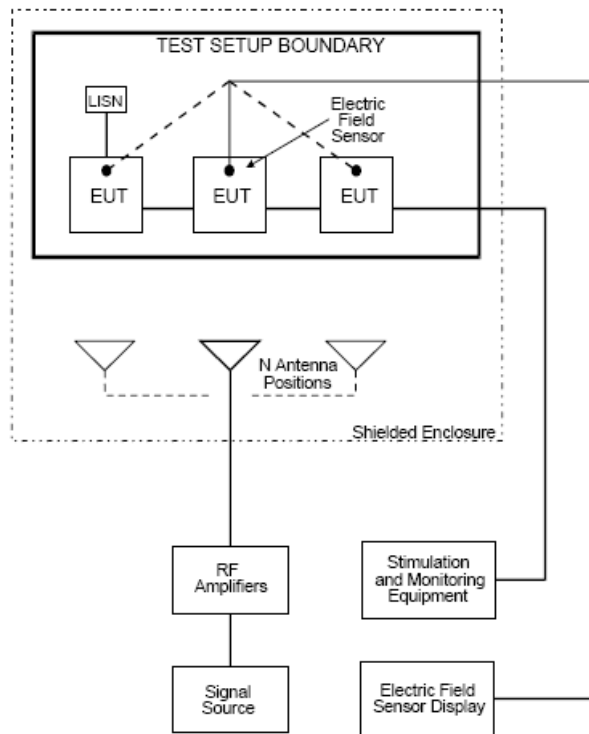

FIGURE RS103-2. Multiple test antenna locations for frequency > 200 MHz

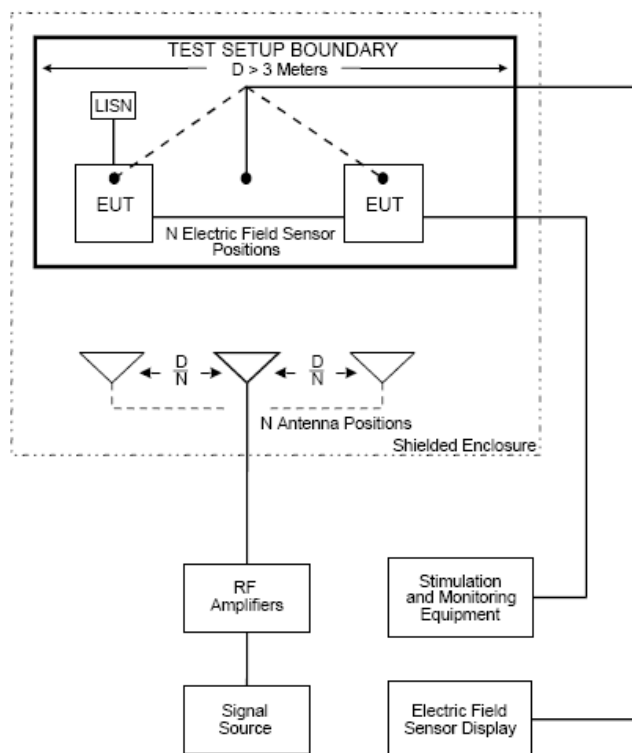

FIGURE RS103-3. Multiple test antenna locations for N positions, $D > 3$ meters