

TEST REPORT

IEC 62368-1

Audio/video, information and communication technology equipment

Part 1: Safety requirements

Report Number : TSSN2306000153L0

Date of issue : 2023-10-24

Total number of pages : 55

Name of Testing Laboratory preparing the Report : Compliance Certification Services Inc. Safety Lab. – Tainan

Applicant's name : 7STARLAKE Co., Ltd.

Address : 2F., No.190, Sec 2, Zhongxing Rd., Xindian Dist., New Taipei City, 23146, Taiwan.

Test specification:

Standard : IEC 62368-1:2014 (Second Edition)
EN 62368-1:2014+A11:2017

Test procedure : LVD of CE

Non-standard test method : N/A

TRF template used : IECEE OD-2020-F1:2020, Ed.1.3

Test Report Form No. : IEC62368_1D

Test Report Form(s) Originator .. : UL(US)

Master TRF : Dated 2021-02-04

Copyright © 2021 IEC System of Conformity Assessment Schemes for Electrotechnical Equipment and Components (IECEE System). All rights reserved.

This publication may be reproduced in whole or in part for non-commercial purposes as long as the IECEE is acknowledged as copyright owner and source of the material. IECEE takes no responsibility for and will not assume liability for damages resulting from the reader's interpretation of the reproduced material due to its placement and context.

If this Test Report Form is used by non-IECEE members, the IECEE/IEC logo and the reference to the CB Scheme procedure shall be removed.

This report is not valid as a CB Test Report unless signed by an approved CB Testing Laboratory and appended to a CB Test Certificate issued by an NCB in accordance with IECEE 02.

General disclaimer:

The test results presented in this report relate only to the object tested.
This report shall not be reproduced, except in full, without the written approval of the Issuing CB Testing Laboratory. The authenticity of this Test Report and its contents can be verified by contacting the NCB, responsible for this Test Report.

Unless otherwise stated the results shown in this test report refer only to the sample(s) tested and such sample(s) are retained for 90 days only.

除非另有說明，此報告結果僅對測試之樣品負責，同時此樣品僅保留 90 天。本報告未經本公司書面許可，不可部份複製。

This document is issued by the Company subject to its General Conditions of Service printed overleaf, available on request or accessible at <http://www.sgs.com.tw/Terms-and-Conditions> and, for electronic format documents, subject to Terms and Conditions for Electronic Documents at <http://www.sgs.com.tw/Terms-and-Conditions>. Attention is drawn to the limitation of liability, indemnification and jurisdiction issues defined therein. Any holder of this document is advised that information contained hereon reflects the Company's findings at the time of its intervention only and within the limits of Client's instructions, if any. The Company's sole responsibility is to its Client and this document does not exonerate parties to a transaction from exercising all their rights and obligations under the transaction documents. This document cannot be reproduced except in full, without prior written approval of the Company. Any unauthorized alteration, forgery or falsification of the content or appearance of this document is unlawful and offenders may be prosecuted to the fullest extent of the law.

SGS Compliance Certification Services Inc. 3F.-1, No. 17, Guoji Rd., Xinshi Dist., Tainan City 744, Taiwan / 台南市新市區國際路 17 號 3 樓之 1

程智科技股份有限公司



t (886-6) 589-2208

f (886-6) 589-2209

www.sgs.com.tw

www.ccsrf.com

Member of SGS Group

Test Item description		Millitary Mission GPU Computer
Trade Mark(s)		7Starlake
Manufacturer		Same as applicant
Model/Type reference		AV600
Ratings		Input: 18-36 V d.c., 20 A
Responsible Testing Laboratory (as applicable), testing procedure and testing location(s):		
<input checked="" type="checkbox"/>	Testing Laboratory:	Compliance Certification Services Inc. Safety Lab. – Tainan
Testing location/ address		3F.-1, No. 17, Guoji Rd., Xinshi Dist., Tainan City 744, Taiwan
Tested by (name, function, signature)		Eason Chiang Project handler 
Approved by (name, function, signature)		Kane Wang Reviewer 
<input type="checkbox"/>	Testing procedure: CTF Stage 1:	
Testing location/ address		
Tested by (name, function, signature)		
Approved by (name, function, signature)		
<input type="checkbox"/>	Testing procedure: CTF Stage 2:	
Testing location/ address		
Tested by (name, function, signature)		
Witnessed by (name, function, signature)		
Approved by (name, function, signature)		
<input type="checkbox"/>	Testing procedure: CTF Stage 3 :	
<input type="checkbox"/>	Testing procedure: CTF Stage 4:	
Testing location/ address		
Tested by (name, function, signature)		
Witnessed by (name, function, signature)		
Approved by (name, function, signature)		
Supervised by (name, function, signature)		

<p>List of Attachments (including a total number of pages in each attachment): Attachment 1: 11 pages of European Group Differences and National Differences Attachment 2: 8 pages of Photographs</p>	
<p>Summary of testing: The sample(s) tested complies with the requirements of EN 62368-1:2014+A11:2017. The investigation of the product did not cover the functional characteristics of the equipment, only the safety aspects as laid out in EN 62368-1 were subjected to the investigation. Tma (max. ambient temperature permitted by the manufacturer's specification.) = 55 degree C Tamb (the ambient temperature under the test, if unless specified.) = 25 degree C Test voltage = 18-36 V d.c. supplied from DC source, it shall be isolated from primary circuits by double/ reinforced insulation and provides ES1 only. This equipment is to be connected only to PoE networks without routing to the outside plant.</p> <p>Maximum normal load: The EUT operated under all connectors connected and transmit data continuously, USB 2.0 port connected with a dummy load of 2.5 W.</p>	
<p>Tests performed (name of test and test clause): 4.4.4.2, T.5 Steady force test 4.4.4.4, T.6 Impact test 5.4.1.4, 6.3.2, 9.2, B.2.6 Temperature measurements 8.6.2.2 Static stability test B.2.5 Input test B.3 Simulated abnormal operating conditions B.4 Simulated single fault conditions F.3.10 Permanence of markings Annex Q.1 Limited power source</p>	<p>Testing location: As page 2.</p>
<p>Summary of compliance with National Differences (List of countries addressed): EU Group Differences, EU Special National Conditions.</p> <p>List of countries addressed CENELEC member countries (EU Group Differences, EU Special National Conditions): Austria, Belgium, Bulgaria, Croatia, Cyprus, the Czech Republic, Denmark, Estonia, Finland, France, Germany, Greece, Hungary, Iceland, Ireland, Italy, Latvia, Lithuania, Luxembourg, Malta, the Netherlands, Norway, Poland, Portugal, Republic of North Macedonia, Romania, Serbia, Slovakia, Slovenia, Spain, Sweden, Switzerland, Turkey and the United Kingdom.</p> <p><input checked="" type="checkbox"/> The product fulfils the requirements of EN 62368-1:2014+A11:2017 <input checked="" type="checkbox"/> The product fulfils the requirements of BS EN 62368-1:2014+A11:2017</p> <p>For National Differences see corresponding Attachment.</p>	

Copy of marking plate:

The artwork below may be only a draft. The use of certification marks on a product must be authorized by the respective NCBs that own these marks.



TEST ITEM PARTICULARS:	
Classification of use by	<input checked="" type="checkbox"/> Ordinary person <input type="checkbox"/> Instructed person <input type="checkbox"/> Skilled person <input type="checkbox"/> Children likely to be present
Supply Connection	<input type="checkbox"/> AC Mains <input type="checkbox"/> DC Mains <input checked="" type="checkbox"/> External Circuit - not Mains connected - <input checked="" type="checkbox"/> ES1 <input type="checkbox"/> ES2 <input type="checkbox"/> ES3
Supply % Tolerance	<input type="checkbox"/> +10%/-10% (for Construction A) <input type="checkbox"/> +20%/-15% <input type="checkbox"/> + ___ %/ - ___ % <input checked="" type="checkbox"/> None
Supply Connection – Type	<input type="checkbox"/> pluggable equipment type A - <input type="checkbox"/> non-detachable supply cord <input type="checkbox"/> appliance coupler <input type="checkbox"/> direct plug-in <input type="checkbox"/> mating connector <input type="checkbox"/> pluggable equipment type B - <input type="checkbox"/> non-detachable supply cord <input type="checkbox"/> appliance coupler <input type="checkbox"/> permanent connection <input type="checkbox"/> mating connector <input checked="" type="checkbox"/> other: Not Mains connected
Considered current rating of protective device as part of building or equipment installation.....	N/A; Installation location: <input checked="" type="checkbox"/> building; <input type="checkbox"/> equipment
Equipment mobility.....	<input checked="" type="checkbox"/> movable <input type="checkbox"/> hand-held <input type="checkbox"/> transportable <input type="checkbox"/> stationary <input type="checkbox"/> for building-in <input type="checkbox"/> direct plug-in <input type="checkbox"/> rack-mounting <input type="checkbox"/> wall-mounted
Over voltage category (OVC)	<input type="checkbox"/> OVC I <input type="checkbox"/> OVC II <input type="checkbox"/> OVC III <input type="checkbox"/> OVC IV <input checked="" type="checkbox"/> other: Not Mains connected
Class of equipment	<input type="checkbox"/> Class I <input type="checkbox"/> Class II <input checked="" type="checkbox"/> Class III <input type="checkbox"/> Class II with functional earthing <input type="checkbox"/> Not classified
Access location	<input type="checkbox"/> restricted access area <input checked="" type="checkbox"/> N/A
Pollution degree (PD)	<input type="checkbox"/> PD 1 <input checked="" type="checkbox"/> PD 2 <input type="checkbox"/> PD 3
Manufacturer’s specified maxium operating ambient	55 °C
IP protection class	<input checked="" type="checkbox"/> IPX0 <input type="checkbox"/> IP___
Power Systems	<input type="checkbox"/> TN <input type="checkbox"/> TT <input type="checkbox"/> IT - ___ V _{L-L} ; <input type="checkbox"/> dc mains <input checked="" type="checkbox"/> N/A
Altitude during operation (m)	<input checked="" type="checkbox"/> 2000 m or less <input type="checkbox"/> ___ m
Altitude of test laboratory (m)	<input checked="" type="checkbox"/> 2000 m or less <input type="checkbox"/> ___ m
Mass of equipment (kg)	<input checked="" type="checkbox"/> 9.8 kg

Possible test case verdicts: - test case does not apply to the test object: N/A - test object does meet the requirement: P (Pass) - test object does not meet the requirement: F (Fail)	
Testing:	
Date of receipt of test item: 2023-06-20	
Date (s) of performance of tests: 2023-07-03 to 2023-10-13	
General remarks:	
"(See Enclosure #)" refers to additional information appended to the report. "(See appended table)" refers to a table appended to the report.	
Throughout this report a <input type="checkbox"/> comma / <input checked="" type="checkbox"/> point is used as the decimal separator.	
<i>This document is issued by the Company subject to its General Conditions of Service printed overleaf, available on request or accessible at https://www.sgs.com.tw/terms-of-service and, for electronic format documents, subject to Terms and Conditions for Electronic Documents at http://www.sgs.com/en/Terms-and-Conditions/Terms-e-Documents.aspx</i>	
<i>Attention is drawn to the limitation of liability, indemnification and jurisdiction issues defined therein. Any holder of this document is advised that information contained hereon reflects the Company's findings at the time of its intervention only and within the limits of Client's instructions, if any. The Company's sole responsibility is to its Client and this document does not exonerate parties to a transaction from exercising all their rights and obligations under the transaction documents. This document cannot be reproduced except in full, without prior written approval of the Company. Any unauthorized alteration, forgery or falsification of the content or appearance of this document is unlawful and offenders may be prosecuted to the fullest extent of the law."</i>	
<i>Unless otherwise stated the results shown in this test report refer only to the sample(s) tested and such sample(s) are retained for 90 days only.</i>	
When determining the test conclusion, if that measure uncertainty is determined according to IEC Guide 115 Cl.4.4.3 figure 2, then the Measurement Uncertainty are not providing.	
All evaluation, test results and judgement in this report are based on information, documents and samples provided by applicant.	
Manufacturer's Declaration per sub-clause 4.2.5 of IEC60060-2:	
The application for obtaining a CB Test Certificate includes more than one factory location and a declaration from the Manufacturer stating that the sample(s) submitted for evaluation is (are) representative of the products from each factory has been provided:	<input type="checkbox"/> Yes <input checked="" type="checkbox"/> Not applicable
When differences exist; they shall be identified in the General product information section.	
Name and address of factory (ies):	7STARLAKE Co., Ltd. 2F., No.190, Sec 2, Zhongxing Rd., Xindian Dist., New Taipei City, 23146, Taiwan.
General product information and other remarks:	

Product Description

1. The equipment under test (EUT), model shown as page 2 is Military Mission GPU Computer for use as audio/video, information and communication technology equipment in the scope of this standard.
2. The equipment is incorporated with following critical parts:
 - 1) Metal enclosure covers all components and fixed by screws.
 - 2) DC/DC converter
 - 3) Main board
 - 4) Connect board
 - 5) I/O board
 - 6) DATA board
 - 7) One SSD
3. The output data port has been evaluated complying with Annex Q.1 as a Limited Power Source.
4. Enclosure opening measurements:

Location	Size (mm)	Comments
Horizontal position:		
Top & Bottom side	--	No openings provide.
Front & Rear side	--	No openings provide.
Right & Left side	--	No openings provide.
Vertical position:		
Top & Bottom side	--	No openings provide.
Front & Rear side	--	No openings provide.
Right & Left side	--	No openings provide.
Supplementary information:		
1) Outside the 15 mm distance from PIS and no PS3 or ES3 parts in 5° projection area of openings.		
2) The rotating parts of the fan are not accessible by the test finger (Figure V.1 and V.2)		

Model Differences

N/A

Technical Considerations

1. The product is in compliance with the requirement of IEC/EN 62368-1.
2. Some components are pre-certified and/or tested, which have been evaluated according to the relevant component requirements of IEC 60950-1, are employed in this product. Their suitability of use has been checked according to subclauses 4.1.1 and 4.1.2.

Additional application considerations – (Considerations used to test a component or sub-assembly) –

N/A

ENERGY SOURCE IDENTIFICATION AND CLASSIFICATION TABLE:	
<p>(Note 1: Identify the following six (6) energy source forms based on the origin of the energy.) (Note 2: The identified classification e.g., ES2, TS1, should be with respect to its ability to cause pain or injury on the body or its ability to ignite a combustible material. Any energy source can be declared Class 3 as a worse case classification e.g. PS3, ES3.)</p>	
<p>Electrically-caused injury (Clause 5): (Note: Identify type of source, list sub-assembly or circuit designation and corresponding energy source classification) Example: +5 V dc input</p>	
ES1	
Source of electrical energy	Corresponding classification (ES)
Input circuit	ES1
Output connectors	ES1
<p>Electrically-caused fire (Clause 6): (Note: List sub-assembly or circuit designation and corresponding energy source classification) Example: Battery pack (maximum 85 watts):</p>	
PS2	
Source of power or PIS	Corresponding classification (PS)
All circuits except for output connectors	PS3
Output connectors	PS2
<p>Injury caused by hazardous substances (Clause 7) (Note: Specify hazardous chemicals, whether produces ozone or other chemical construction not addressed as part of the component evaluation.) Example: Liquid in filled component</p>	
Glycol	
Source of hazardous substances	Corresponding chemical
Lithium coin battery	Lithium
<p>Mechanically-caused injury (Clause 8) (Note: List moving part(s), fan, special installations, etc. & corresponding MS classification based on Table 35.) Example: Wall mount unit</p>	
MS2	
Source of kinetic/mechanical energy	Corresponding classification (MS)
Sharp edges and corners	MS1
Equipment mass, Mass of 9.8 Kg	MS2
<p>Thermal burn injury (Clause 9) (Note: Identify the surface or support, and corresponding energy source classification based on type of part, location, operating temperature and contact time in Table 38.) Example: Hand-held scanner – thermoplastic enclosure</p>	
TS1	
Source of thermal energy	Corresponding classification (TS)
Accessible parts	TS1
<p>Radiation (Clause 10) (Note: List the types of radiation present in the product and the corresponding energy source classification.) Example: DVD – Class 1 Laser Product</p>	
RS1	
Type of radiation	Corresponding classification (RS)
The LED is used as indicating light	RS1

ENERGY SOURCE DIAGRAM
Indicate which energy sources are included in the energy source diagram. Insert diagram below
<p>See “ ENERGY SOURCE IDENTIFICATION AND CLASSIFICATION TABLE ”</p> <p style="margin-top: 20px;"> <input type="checkbox"/> ES <input type="checkbox"/> PS <input type="checkbox"/> MS <input type="checkbox"/> TS <input type="checkbox"/> RS </p>

OVERVIEW OF EMPLOYED SAFEGUARDS				
Clause	Possible Hazard			
5.1	Electrically-caused injury			
Body Part (e.g. Ordinary)	Energy Source (ES3: Primary Filter circuit)	Safeguards		
		Basic	Supplementary	Reinforced (Enclosure)
Ordinary	ES1: Internal circuit	N/A	N/A	N/A
Ordinary	ES1: Output connectors	N/A	N/A	N/A
6.1	Electrically-caused fire			
Material part (e.g. mouse enclosure)	Energy Source (PS2: 100 Watt circuit)	Safeguards		
		Basic	Supplementary	Reinforced
Enclosure	PS3 circuit	See sub-clause 6.3	Metal	N/A
PCB	PS3 circuit	See sub-clause 6.3	V-1 or better	N/A
The other components/ combustible materials	PS3 circuit	See sub-clause 6.3	See sub-clauses 6.4.5 and 6.4.6	N/A
Internal wiring	PS3 circuit	N/A	N/A	See 6.5
Output connectors	PS2 circuit	See sub-clause 6.3	See sub-clauses 6.4.5 and 6.4.6	N/A
7.1	Injury caused by hazardous substances			
Body Part (e.g., skilled)	Energy Source (hazardous material)	Safeguards		
		Basic	Supplementary	Reinforced
Ordinary	Lithium coin battery	Complies with 4.8	N/A	N/A
8.1	Mechanically-caused injury			
Body Part (e.g. Ordinary)	Energy Source (MS3: High Pressure Lamp)	Safeguards		
		Basic	Supplementary	Reinforced (Enclosure)
Ordinary	MS1: The edges will not cause injury in normal condition.	N/A	N/A	N/A

Ordinary	MS2: Equipment mass > 7 kg; ≤ 25 kg.	Equipment safeguard	N/A	N/A
9.1	Thermal Burn			
Body Part (e.g., Ordinary)	Energy Source (TS2)	Safeguards		
		Basic	Supplementary	Reinforced
Ordinary	TS1: Accessible parts	N/A	N/A	N/A
10.1	Radiation			
Body Part (e.g., Ordinary)	Energy Source (Output from audio port)	Safeguards		
		Basic	Supplementary	Reinforced
Ordinary	RS1: LED (indicating light)	N/A	N/A	N/A
Supplementary Information:				
(1) See attached energy source diagram for additional details.				
(2) "N" – Normal Condition; "A" – Abnormal Condition; "S" Single Fault				

IEC 62368-1			
Clause	Requirement + Test	Result - Remark	Verdict
4	GENERAL REQUIREMENTS		—
4.1.1	Acceptance of materials, components and subassemblies	See appended Table 4.1.2	P
4.1.2	Use of components	Components which are certified to IEC and/or national standards are used correctly within their ratings. Components not covered by IEC standards are tested under the conditions present in the equipment.	P
4.1.3	Equipment design and construction	No accessible part which could cause injury.	P
4.1.15	Markings and instructions.....:	(See Annex F)	P
4.4.4	Safeguard robustness	See below.	P
4.4.4.2	Steady force tests.....:	(See Annex T.5)	P
4.4.4.3	Drop tests.....:		N/A
4.4.4.4	Impact tests.....:	(See Annex T.6)	P
4.4.4.5	Internal accessible safeguard enclosure and barrier tests.....:		N/A
4.4.4.6	Glass Impact tests.....:		N/A
4.4.4.7	Thermoplastic material tests.....:		N/A
4.4.4.8	Air comprising a safeguard.....:		N/A
4.4.4.9	Accessibility and safeguard effectiveness		P
4.5	Explosion		N/A
4.6	Fixing of conductors	No conductors requiring safeguard.	N/A
4.6.1	Fix conductors not to defeat a safeguard		N/A
4.6.2	10 N force test applied to.....:		N/A
4.7	Equipment for direct insertion into mains socket - outlets	Not direct plug-in equipment.	N/A
4.7.2	Mains plug part complies with the relevant standard.....:		N/A
4.7.3	Torque (Nm).....:		N/A
4.8	Products containing coin/button cell batteries	The children are unlikely present in the equipment location.	N/A
4.8.2	Instructional safeguard		N/A
4.8.3	Battery Compartment Construction		N/A
	Means to reduce the possibility of children removing the battery.....:		—
4.8.4	Battery Compartment Mechanical Tests.....:		N/A

IEC 62368-1			
Clause	Requirement + Test	Result - Remark	Verdict
4.8.5	Battery Accessibility		N/A
4.9	Likelihood of fire or shock due to entry of conductive object.....:	(See Annex P)	P

5	ELECTRICALLY-CAUSED INJURY		—
5.2.1	Electrical energy source classifications :	Whole circuit throughout this equipment are supplied by ES1.	P
5.2.2	ES1, ES2 and ES3 limits	See below.	P
5.2.2.2	Steady-state voltage and current :	ES1 is considered.	P
5.2.2.3	Capacitance limits :		N/A
5.2.2.4	Single pulse limits :		N/A
5.2.2.5	Limits for repetitive pulses :		N/A
5.2.2.6	Ringling signals :		N/A
5.2.2.7	Audio signals :		N/A
5.3	Protection against electrical energy sources		N/A
5.3.1	General Requirements for accessible parts to ordinary, instructed and skilled persons		N/A
5.3.2.1	Accessibility to electrical energy sources and safeguards		N/A
5.3.2.2	Contact requirements		N/A
	a) Test with test probe from Annex V :		N/A
	b) Electric strength test potential (V) :		N/A
	c) Air gap (mm) :		N/A
5.3.2.4	Terminals for connecting stripped wire		N/A
5.4	Insulation materials and requirements		N/A
5.4.1.2	Properties of insulating material	Class III equipment that only containing functional insulation.	N/A
5.4.1.3	Humidity conditioning.....:		N/A
5.4.1.4	Maximum operating temperature for insulating materials.....:		N/A
5.4.1.5	Pollution degree.....:	2	—
5.4.1.5.2	Test for pollution degree 1 environment and for an insulating compound		N/A
5.4.1.5.3	Thermal cycling		N/A
5.4.1.6	Insulation in transformers with varying dimensions		N/A
5.4.1.7	Insulation in circuits generating starting pulses		N/A
5.4.1.8	Determination of working voltage		N/A
5.4.1.9	Insulating surfaces		N/A

IEC 62368-1			
Clause	Requirement + Test	Result - Remark	Verdict
5.4.1.10	Thermoplastic parts on which conductive metallic parts are directly mounted		N/A
5.4.1.10.2	Vicat softening temperature..... :		N/A
5.4.1.10.3	Ball pressure :		N/A
5.4.2	Clearances	Only functional insulation is considered and complied with Annex B.4.4	N/A
5.4.2.2	Determining clearance using peak working voltage		N/A
5.4.2.3	Determining clearance using required withstand voltage :		N/A
	a) a.c. mains transient voltage :		—
	b) d.c. mains transient voltage :		—
	c) external circuit transient voltage :		—
	d) transient voltage determined by measurement :		—
5.4.2.4	Determining the adequacy of a clearance using an electric strength test		N/A
5.4.2.5	Multiplication factors for clearances and test voltages :	Only functional insulation is considered and complied with Annex B.4.4	N/A
5.4.3	Creepage distances :		N/A
5.4.3.1	General		N/A
5.4.3.3	Material Group :		—
5.4.4	Solid insulation		N/A
5.4.4.2	Minimum distance through insulation :		N/A
5.4.4.3	Insulation compound forming solid insulation		N/A
5.4.4.4	Solid insulation in semiconductor devices		N/A
5.4.4.5	Cemented joints		N/A
5.4.4.6	Thin sheet material		N/A
5.4.4.6.1	General requirements		N/A
5.4.4.6.2	Separable thin sheet material		N/A
	Number of layers (pcs) :		N/A
5.4.4.6.3	Non-separable thin sheet material		N/A
5.4.4.6.4	Standard test procedure for non-separable thin sheet material :		N/A
5.4.4.6.5	Mandrel test		N/A
5.4.4.7	Solid insulation in wound components		N/A
5.4.4.9	Solid insulation at frequencies >30 kHz :		N/A

IEC 62368-1			
Clause	Requirement + Test	Result - Remark	Verdict
5.4.5	Antenna terminal insulation	No such parts.	N/A
5.4.5.1	General		N/A
5.4.5.2	Voltage surge test		N/A
	Insulation resistance (MΩ)..... :		—
5.4.6	Insulation of internal wire as part of supplementary safeguard..... :	No such parts.	N/A
5.4.7	Tests for semiconductor components and for cemented joints	No such parts.	N/A
5.4.8	Humidity conditioning	See 5.4.1.2	N/A
	Relative humidity (%)..... :		—
	Temperature (°C) :		—
	Duration (h) :		—
5.4.9	Electric strength test..... :	No protection against electrical shock deemed necessary to ES1 energy source.	N/A
5.4.9.1	Test procedure for a solid insulation type test		N/A
5.4.9.2	Test procedure for routine tests		N/A
5.4.10	Protection against transient voltages between external circuit	No such circuits.	N/A
5.4.10.1	Parts and circuits separated from external circuits		N/A
5.4.10.2	Test methods		N/A
5.4.10.2.1	General		N/A
5.4.10.2.2	Impulse test :		N/A
5.4.10.2.3	Steady-state test..... :		N/A
5.4.11	Insulation between external circuits and earthed circuitry :	No such parts.	N/A
5.4.11.1	Exceptions to separation between external circuits and earth		N/A
5.4.11.2	Requirements		N/A
	Rated operating voltage U_{op} (V) :		—
	Nominal voltage U_{peak} (V) :		—
	Max increase due to variation U_{sp} :		—
	Max increase due to ageing ΔU_{sa} :		—
	$U_{op} = U_{peak} + \Delta U_{sp} + \Delta U_{sa}$:		—
5.5	Components as safeguards		N/A
5.5.1	General	No component used as safeguard.	N/A
5.5.2	Capacitors and RC units	No capacitors and RC units.	N/A

IEC 62368-1			
Clause	Requirement + Test	Result - Remark	Verdict
5.5.2.1	General requirement		N/A
5.5.2.2	Safeguards against capacitor discharge after disconnection of a connector.....:		N/A
5.5.3	Transformers	No transformers.	N/A
5.5.4	Optocouplers	No optocouplers.	N/A
5.5.5	Relays	No relays.	N/A
5.5.6	Resistors	No such resistors.	N/A
5.5.7	SPD's	No SPD's.	N/A
5.5.7.1	Use of an SPD connected to reliable earthing		N/A
5.5.7.2	Use of an SPD between mains and protective earth		N/A
5.5.8	Insulation between the mains and external circuit consisting of a coaxial cable.....:	No such parts.	N/A
5.6	Protective conductor		N/A
5.6.2	Requirement for protective conductors	Class III equipment.	N/A
5.6.2.1	General requirements		N/A
5.6.2.2	Colour of insulation		N/A
5.6.3	Requirement for protective earthing conductors		N/A
	Protective earthing conductor size (mm ²)		—
5.6.4	Requirement for protective bonding conductors		N/A
5.6.4.1	Protective bonding conductors		N/A
	Protective bonding conductor size (mm ²).		—
	Protective current rating (A)		—
5.6.4.3	Current limiting and overcurrent protective devices		N/A
5.6.5	Terminals for protective conductors		N/A
5.6.5.1	Requirement		N/A
	Conductor size (mm ²), nominal thread diameter (mm).		N/A
5.6.5.2	Corrosion		N/A
5.6.6	Resistance of the protective system		N/A
5.6.6.1	Requirements		N/A
5.6.6.2	Test Method Resistance (Ω).....:		N/A
5.6.7	Reliable earthing	Class III equipment.	N/A
5.7	Prospective touch voltage, touch current and protective conductor current		N/A

IEC 62368-1			
Clause	Requirement + Test	Result - Remark	Verdict
5.7.2	Measuring devices and networks	Class III equipment, all prospective touch voltage inside the equipment is ES1.	N/A
5.7.2.1	Measurement of touch current		N/A
5.7.2.2	Measurement of prospective touch voltage		N/A
5.7.3	Equipment set-up, supply connections and earth connections		N/A
	System of interconnected equipment (separate connections/single connection)		—
	Multiple connections to mains (one connection at a time/simultaneous connections)		—
5.7.4	Earthed conductive accessible parts	Class III equipment.	N/A
5.7.5	Protective conductor current		N/A
	Supply Voltage (V)		—
	Measured current (mA)		—
	Instructional Safeguard		N/A
5.7.6	Prospective touch voltage and touch current due to external circuits		N/A
5.7.6.1	Touch current from coaxial cables		N/A
5.7.6.2	Prospective touch voltage and touch current from external circuits		N/A
5.7.7	Summation of touch currents from external circuits		N/A
	a) Equipment with earthed external circuits Measured current (mA)		—
	b) Equipment whose external circuits are not referenced to earth. Measured current (mA)		—

6	ELECTRICALLY- CAUSED FIRE		—
6.2	Classification of power sources (PS) and potential ignition sources (PIS)		P
6.2.2	Power source circuit classifications	Considered as PS3 and no further test considered necessary.	P
6.2.2.1	General	See below.	P
6.2.2.2	Power measurement for worst-case load fault ... :	See 6.2.2	P
6.2.2.3	Power measurement for worst-case power source fault	See 6.2.2	P
6.2.2.4	PS1	See 6.2.2	N/A
6.2.2.5	PS2	See 6.2.2	P
6.2.2.6	PS3	See 6.2.2	P

IEC 62368-1			
Clause	Requirement + Test	Result - Remark	Verdict
6.2.3	Classification of potential ignition sources	See below.	P
6.2.3.1	Arcing PIS	No such PIS.	N/A
6.2.3.2	Resistive PIS	All components located within the equipment are considered as resistive PIS. No further test considered necessary	P
6.3	Safeguards against fire under normal operating and abnormal operating conditions		P
6.3.1 (a)	No ignition and attainable temperature value less than 90 % defined by ISO 871 or less than 300 °C for unknown materials.....	During the test, no ignition occurred, or component's temperature reach to 300 °C of spontaneous ignition point.	P
6.3.1 (b)	Combustible materials outside fire enclosure	No such parts.	N/A
6.4	Safeguards against fire under single fault conditions		P
6.4.1	Safeguard Method	Method of "control of fire spread" is used.	P
6.4.2	Reduction of the likelihood of ignition under single fault conditions in PS1 circuits		N/A
6.4.3	Reduction of the likelihood of ignition under single fault conditions in PS2 and PS3 circuits		N/A
6.4.3.1	General		N/A
6.4.3.2	Supplementary Safeguards		N/A
	Special conditions if conductors on printed boards are opened or peeled		N/A
6.4.3.3	Single Fault Conditions.....		N/A
	Special conditions for temperature limited by fuse		N/A
6.4.4	Control of fire spread in PS1 circuits		N/A
6.4.5	Control of fire spread in PS2 circuits	See below.	P
6.4.5.2	Supplementary safeguards	Components other than PCB and wires are: - mounted on PCB min, V-1 or - made of V-2/VTM-2 or better. (See appended Table 4.1.2 and Annex G)	P
6.4.6	Control of fire spread in PS3 circuit	See 6.4.5.2	P
6.4.7	Separation of combustible materials from a PIS	See 6.4.5	N/A
6.4.7.1	General.....		N/A
6.4.7.2	Separation by distance		N/A
6.4.7.3	Separation by a fire barrier		N/A
6.4.8	Fire enclosures and fire barriers	Equipment enclosure was evaluated as a fire enclosure.	P

IEC 62368-1			
Clause	Requirement + Test	Result - Remark	Verdict
6.4.8.1	Fire enclosure and fire barrier material properties	See below.	P
6.4.8.2.1	Requirements for a fire barrier		N/A
6.4.8.2.2	Requirements for a fire enclosure	Equipment fire enclosure was made of metal.	P
6.4.8.3	Constructional requirements for a fire enclosure and a fire barrier	See below.	P
6.4.8.3.1	Fire enclosure and fire barrier openings	See below.	P
6.4.8.3.2	Fire barrier dimensions		N/A
6.4.8.3.3	Top Openings in Fire Enclosure: dimensions (mm)	The openings do not exceed 5 mm in any dimension or 1 mm in width regardless of length or the openings were outside the fire cone of 15 mm. (See Product Description: Enclosure opening measurements for details.)	P
	Needle Flame test		N/A
6.4.8.3.4	Bottom Openings in Fire Enclosure, condition met a), b) and/or c) dimensions (mm)	The openings do not exceed 3 mm in any dimension or 1 mm in width regardless of length or the openings were outside the fire cone of 15 mm. (See Product Description: Enclosure opening measurements for details.)	P
	Flammability tests for the bottom of a fire enclosure		N/A
6.4.8.3.5	Integrity of the fire enclosure, condition met: a), b) or c)		N/A
6.4.8.4	Separation of PIS from fire enclosure and fire barrier distance (mm) or flammability rating	The metal enclosure is considered as fire enclosure.	P
6.5	Internal and external wiring		P
6.5.1	Requirements	VW-1 wire used. The test method described IEC60695-11-21 is considered.	P
6.5.2	Cross-sectional area (mm ²)		—
6.5.3	Requirements for interconnection to building wiring		N/A
6.6	Safeguards against fire due to connection to additional equipment	See below.	P
	External port limited to PS2 or complies with Clause Q.1	Complied with Table Annex Q.1.	P

IEC 62368-1			
Clause	Requirement + Test	Result - Remark	Verdict
7	INJURY CAUSED BY HAZARDOUS SUBSTANCES		—
7.2	Reduction of exposure to hazardous substances		N/A
7.3	Ozone exposure		N/A
7.4	Use of personal safeguards (PPE)		N/A
	Personal safeguards and instructions		—
7.5	Use of instructional safeguards and instructions		N/A
	Instructional safeguard (ISO 7010)		—
7.6	Batteries.....	(See Annex M)	P

8	MECHANICALLY-CAUSED INJURY		—
8.1	General	See below.	P
8.2	Mechanical energy source classifications	See energy source identification and classification table.	P
8.3	Safeguards against mechanical energy sources		N/A
8.4	Safeguards against parts with sharp edges and corners	MS1	P
8.4.1	Safeguards		N/A
8.5	Safeguards against moving parts	No moving parts.	N/A
8.5.1	MS2 or MS3 part required to be accessible for the function of the equipment		N/A
8.5.2	Instructional Safeguard		—
8.5.4	Special categories of equipment comprising moving parts		N/A
8.5.4.1	Large data storage equipment		N/A
8.5.4.2	Equipment having electromechanical device for destruction of media		N/A
8.5.4.2.1	Safeguards and Safety Interlocks		N/A
8.5.4.2.2	Instructional safeguards against moving parts		N/A
	Instructional Safeguard		—
8.5.4.2.3	Disconnection from the supply		N/A
8.5.4.2.4	Probe type and force (N)		N/A
8.5.5	High Pressure Lamps		N/A
8.5.5.1	Energy Source Classification		N/A
8.5.5.2	High Pressure Lamp Explosion Test.....		N/A
8.6	Stability	See below.	P
8.6.1	Product classification	MS2.	P

IEC 62368-1			
Clause	Requirement + Test	Result - Remark	Verdict
	Instructional Safeguard.....:		—
8.6.2	Static stability	See below.	P
8.6.2.2	Static stability test	Test with angle of 10°	P
	Applied Force.....:	Not required.	—
8.6.2.3	Downward Force Test		N/A
8.6.3	Relocation stability test		N/A
	Unit configuration during 10° tilt.....:		—
8.6.4	Glass slide test		N/A
8.6.5	Horizontal force test (Applied Force).....:		N/A
	Position of feet or movable parts.....:		—
8.7	Equipment mounted to wall or ceiling	No such parts.	N/A
8.7.1	Mounting Means (Length of screws (mm) and mounting surface).....:		N/A
8.7.2	Direction and applied force.....:		N/A
8.8	Handles strength	No handle in the equipment.	N/A
8.8.1	Classification		N/A
8.8.2	Applied Force.....:		N/A
8.9	Wheels or casters attachment requirements	No wheels or casters in the equipment.	N/A
8.9.1	Classification		N/A
8.9.2	Applied force.....:		—
8.10	Carts, stands and similar carriers	No carts, stands and similar carriers in the equipment.	N/A
8.10.1	General		N/A
8.10.2	Marking and instructions		N/A
	Instructional Safeguard.....:		—
8.10.3	Cart, stand or carrier loading test and compliance		N/A
	Applied force.....:		—
8.10.4	Cart, stand or carrier impact test		N/A
8.10.5	Mechanical stability		N/A
	Applied horizontal force (N).....:		—
8.10.6	Thermoplastic temperature stability (°C).....:		N/A
8.11	Mounting means for rack mounted equipment	No such parts.	N/A
8.11.1	General		N/A
8.11.2	Product Classification		N/A
8.11.3	Mechanical strength test, variable N.....:		N/A

IEC 62368-1			
Clause	Requirement + Test	Result - Remark	Verdict
8.11.4	Mechanical strength test 250N, including end stops		N/A
8.12	Telescoping or rod antennas	No such parts.	N/A
	Button/Ball diameter (mm)		—

9	THERMAL BURN INJURY		—
9.2	Thermal energy source classifications	The accessible surfaces are classified as TS1. See appended table 5.4.1.4, 6.3.2, 9.0, B.2.6.	P
9.3	Safeguard against thermal energy sources		N/A
9.4	Requirements for safeguards		N/A
9.4.1	Equipment safeguard	Not required due to TS1.	N/A
9.4.2	Instructional safeguard		N/A

10	RADIATION		—
10.2	Radiation energy source classification	See below	P
10.2.1	General classification	LED indicator is considered as RS1.	P
10.3	Protection against laser radiation	No such parts.	N/A
	Laser radiation that exists in the equipment:		—
	Normal, abnormal, single-fault.....		N/A
	Instructional safeguard		—
	Tool.....		—
10.4	Protection against visible, infrared, and UV radiation	No such parts.	N/A
10.4.1	General		N/A
10.4.1.a)	RS3 for Ordinary and instructed persons		N/A
10.4.1.b)	RS3 accessible to a skilled person.....		N/A
	Personal safeguard (PPE) instructional safeguard.....		—
10.4.1.c)	Equipment visible, IR, UV does not exceed RS1. :		N/A
10.4.1.d)	Normal, abnormal, single-fault conditions		N/A
10.4.1.e)	Enclosure material employed as safeguard is opaque.....		N/A
10.4.1.f)	UV attenuation.....		N/A
10.4.1.g)	Materials resistant to degradation UV		N/A
10.4.1.h)	Enclosure containment of optical radiation.....		N/A

IEC 62368-1			
Clause	Requirement + Test	Result - Remark	Verdict
10.4.1.i)	Exempt Group under normal operating conditions..... :		N/A
10.4.2	Instructional safeguard :		N/A
10.5	Protection against x-radiation	No such parts.	N/A
10.5.1	X- radiation energy source that exists equipment :		N/A
	Normal, abnormal, single fault conditions		N/A
	Equipment safeguards..... :		N/A
	Instructional safeguard for skilled person :		N/A
10.5.3	Most unfavourable supply voltage to give maximum radiation :		—
	Abnormal and single-fault condition :		N/A
	Maximum radiation (pA/kg)..... :		N/A
10.6	Protection against acoustic energy sources	No such parts.	N/A
10.6.1	General		N/A
10.6.2	Classification		N/A
	Acoustic output, dB(A)..... :		N/A
	Output voltage, unweighted r.m.s..... :		N/A
10.6.4	Protection of persons		N/A
	Instructional safeguards :		N/A
	Equipment safeguard prevent ordinary person to RS2..... :		—
	Means to actively inform user of increase sound pressure..... :		—
	Equipment safeguard prevent ordinary person to RS2..... :		—
10.6.5	Requirements for listening devices (headphones, earphones, etc.)		N/A
10.6.5.1	Corded passive listening devices with analog input		N/A
	Input voltage with 94 dB(A) L_{Aeq} acoustic pressure output..... :		—
10.6.5.2	Corded listening devices with digital input		N/A
	Maximum dB(A)..... :		—
10.6.5.3	Cordless listening device		N/A
	Maximum dB(A)..... :		—

IEC 62368-1			
Clause	Requirement + Test	Result - Remark	Verdict
B	NORMAL OPERATING CONDITION TESTS, ABNORMAL OPERATING CONDITION TESTS AND SINGLE FAULT CONDITION TESTS		—
B.2	Normal Operating Conditions	Considered.	P
B.2.1	General requirements..... :	(See Test Item Particulars and appended test tables)	P
	Audio Amplifiers and equipment with audio amplifiers	No amplifiers.	N/A
B.2.3	Supply voltage and tolerances	Not connected to mains.	N/A
B.2.5	Input test..... :	(See appended table B.2.5)	P
B.3	Simulated abnormal operating conditions		P
B.3.1	General requirements..... :	See below.	P
B.3.2	Covering of ventilation openings	No openings.	N/A
B.3.3	D.C. mains polarity test	Not connected to D.C. mains.	N/A
B.3.4	Setting of voltage selector	No voltage select switch.	N/A
B.3.5	Maximum load at output terminals	(See appended table B.3)	P
B.3.6	Reverse battery polarity		N/A
B.3.7	Abnormal operating conditions as specified in Clause E.2.		N/A
B.3.8	Safeguards functional during and after abnormal operating conditions		N/A
B.4	Simulated single fault conditions		P
B.4.2	Temperature controlling device open or short-circuited	No such parts.	N/A
B.4.3	Motor tests	No motor.	N/A
B.4.3.1	Motor blocked or rotor locked increasing the internal ambient temperature		N/A
B.4.4	Short circuit of functional insulation	See below.	P
B.4.4.1	Short circuit of clearances for functional insulation	(See appended table B.4)	P
B.4.4.2	Short circuit of creepage distances for functional insulation	(See appended table B.4)	P
B.4.4.3	Short circuit of functional insulation on coated printed boards	No such parts.	N/A
B.4.5	Short circuit and interruption of electrodes in tubes and semiconductors	No such parts.	N/A
B.4.6	Short circuit or disconnect of passive components	(See appended table B.4)	P
B.4.7	Continuous operation of components		N/A
B.4.8	Class 1 and Class 2 energy sources within limits during and after single fault conditions	(See appended table B.4)	P
B.4.9	Battery charging under single fault conditions ... :		N/A

IEC 62368-1			
Clause	Requirement + Test	Result - Remark	Verdict

C	UV RADIATION		—
C.1	Protection of materials in equipment from UV radiation	No such radiation.	N/A
C.1.2	Requirements		N/A
C.1.3	Test method		N/A
C.2	UV light conditioning test		N/A
C.2.1	Test apparatus		N/A
C.2.2	Mounting of test samples		N/A
C.2.3	Carbon-arc light-exposure apparatus		N/A
C.2.4	Xenon-arc light exposure apparatus		N/A

D	TEST GENERATORS		—
D.1	Impulse test generators	Not used.	N/A
D.2	Antenna interface test generator		N/A
D.3	Electronic pulse generator		N/A

E	TEST CONDITIONS FOR EQUIPMENT CONTAINING AUDIO AMPLIFIERS		—
E.1	Audio amplifier normal operating conditions	No amplifier.	N/A
	Audio signal voltage (V)		—
	Rated load impedance (Ω)		—
E.2	Audio amplifier abnormal operating conditions		N/A

F	EQUIPMENT MARKINGS, INSTRUCTIONS, AND INSTRUCTIONAL SAFEGUARDS		—
F.1	General requirements	See below.	P
	Instructions – Language	English.	—
F.2	Letter symbols and graphical symbols	No such symbols used in instruction or marking plate.	N/A
F.2.1	Letter symbols according to IEC60027-1		N/A
F.2.2	Graphic symbols IEC, ISO or manufacturer specific		N/A
F.3	Equipment markings		P
F.3.1	Equipment marking locations	Marking plate placed on equipment outer surface.	P
F.3.2	Equipment identification markings		P
F.3.2.1	Manufacturer identification	See copy of marking plate.	—

IEC 62368-1			
Clause	Requirement + Test	Result - Remark	Verdict
F.3.2.2	Model identification	See copy of marking plate.	—
F.3.3	Equipment rating markings	See below.	P
F.3.3.1	Equipment with direct connection to mains		N/A
F.3.3.2	Equipment without direct connection to mains	Equipment is not directly connected to the mains.	P
F.3.3.3	Nature of supply voltage.....	See copy of marking plate.	—
F.3.3.4	Rated voltage	See copy of marking plate.	—
F.3.3.5	Rated frequency		—
F.3.3.6	Rated current or rated power	See copy of marking plate.	—
F.3.3.7	Equipment with multiple supply connections		N/A
F.3.4	Voltage setting device		N/A
F.3.5	Terminals and operating devices		N/A
F.3.5.1	Mains appliance outlet and socket-outlet markings		N/A
F.3.5.2	Switch position identification marking		N/A
F.3.5.3	Replacement fuse identification and rating markings		N/A
F.3.5.4	Replacement battery identification marking		N/A
F.3.5.5	Terminal marking location		N/A
F.3.6	Equipment markings related to equipment classification	Class III equipment.	N/A
F.3.6.1	Class I Equipment		N/A
F.3.6.1.1	Protective earthing conductor terminal		N/A
F.3.6.1.2	Neutral conductor terminal		N/A
F.3.6.1.3	Protective bonding conductor terminals		N/A
F.3.6.2	Class II equipment (IEC60417-5172)		N/A
F.3.6.2.1	Class II equipment with or without functional earth		N/A
F.3.6.2.2	Class II equipment with functional earth terminal marking		N/A
F.3.7	Equipment IP rating marking	IPX0	—
F.3.8	External power supply output marking		N/A
F.3.9	Durability, legibility and permanence of marking	The marking on equipment is durability, legibility and easy to be identified by ordinary person.	P

IEC 62368-1			
Clause	Requirement + Test	Result - Remark	Verdict
F.3.10	Test for permanence of markings	The marking plate was subjected to the permanence of marking test. The marking plate was rubbed with cloth soaked with water for 15 s and then again for 15 s with the cloth soaked with petroleum spirit. After each test, there was no damage to the marking plate. The marking on the label did not fade. There was no curling of the marking plate and removed by hand.	P
F.4	Instructions		P
	a) Equipment for use in locations where children not likely to be present - marking		N/A
	b) Instructions given for installation or initial use	Compliance.	P
	c) Equipment intended to be fastened in place		N/A
	d) Equipment intended for use only in restricted access area		N/A
	e) Audio equipment terminals classified as ES3 and other equipment with terminals marked in accordance F.3.6.1		N/A
	f) Protective earthing employed as safeguard		N/A
	g) Protective earthing conductor current exceeding ES 2 limits		N/A
	h) Symbols used on equipment		N/A
	i) Permanently connected equipment not provided with all-pole mains switch		N/A
	j) Replaceable components or modules providing safeguard function		N/A
F.5	Instructional safeguards		N/A
	Where "instructional safeguard" is referenced in the test report it specifies the required elements, location of marking and/or instruction		N/A

G	COMPONENTS		—
G.1	Switches		N/A
G.1.1	General requirements	No such parts.	N/A
G.1.2	Ratings, endurance, spacing, maximum load		N/A
G.2	Relays		N/A
G.2.1	General requirements	No such parts.	N/A
G.2.2	Overload test		N/A

IEC 62368-1			
Clause	Requirement + Test	Result - Remark	Verdict
G.2.3	Relay controlling connectors supply power		N/A
G.2.4	Mains relay, modified as stated in G.2		N/A
G.3	Protection Devices		N/A
G.3.1	Thermal cut-offs		N/A
G.3.1.1a) &b)	Thermal cut-outs separately approved according to IEC 60730 with conditions indicated in a) & b)		N/A
G.3.1.1c)	Thermal cut-outs tested as part of the equipment as indicated in c)		N/A
G.3.1.2	Thermal cut-off connections maintained and secure		N/A
G.3.2	Thermal links		N/A
G.3.2.1a)	Thermal links separately tested with IEC 60691	No such parts.	N/A
G.3.2.1b)	Thermal links tested as part of the equipment		N/A
	Aging hours (H)		—
	Single Fault Condition		—
	Test Voltage (V) and Insulation Resistance (Ω) . :		—
G.3.3	PTC Thermistors	Approved component used.	P
G.3.4	Overcurrent protection devices	No such parts.	N/A
G.3.5	Safeguards components not mentioned in G.3.1 to G.3.5		N/A
G.3.5.1	Non-resettable devices suitably rated and marking provided		N/A
G.3.5.2	Single faults conditions.....:		N/A
G.4	Connectors		N/A
G.4.1	Spacings		N/A
G.4.2	Mains connector configuration		N/A
G.4.3	Plug is shaped that insertion into mains socket-outlets or appliance coupler is unlikely		N/A
G.5	Wound Components		N/A
G.5.1	Wire insulation in wound components.....	No such parts.	N/A
G.5.1.2 a)	Two wires in contact inside wound component, angle between 45° and 90°		N/A
G.5.1.2 b)	Construction subject to routine testing		N/A
G.5.2	Endurance test on wound components		N/A
G.5.2.1	General test requirements		N/A
G.5.2.2	Heat run test		N/A
	Time (s)		—
	Temperature (°C)		—

IEC 62368-1			
Clause	Requirement + Test	Result - Remark	Verdict
G.5.2.3	Wound Components supplied by mains		N/A
G.5.3	Transformers		N/A
G.5.3.1	Requirements applied (IEC61204-7, IEC61558-1/-2, and/or IEC62368-1)..... :	No such parts.	N/A
	Position..... :		—
	Method of protection :		—
G.5.3.2	Insulation		N/A
	Protection from displacement of windings..... :		—
G.5.3.3	Overload test :		N/A
G.5.3.3.1	Test conditions		N/A
G.5.3.3.2	Winding Temperatures testing in the unit		N/A
G.5.3.3.3	Winding Temperatures - Alternative test method		N/A
G.5.4	Motors		N/A
G.5.4.1	General requirements	No such parts.	N/A
	Position :		—
G.5.4.2	Test conditions		N/A
G.5.4.3	Running overload test		N/A
G.5.4.4	Locked-rotor overload test		N/A
	Test duration (days) :		—
G.5.4.5	Running overload test for d.c. motors in secondary circuits		N/A
G.5.4.5.2	Tested in the unit		N/A
	Electric strength test (V)..... :		—
G.5.4.5.3	Tested on the Bench - Alternative test method; test time (h) :		N/A
	Electric strength test (V)..... :		—
G.5.4.6	Locked-rotor overload test for d.c. motors in secondary circuits		N/A
G.5.4.6.2	Tested in the unit		N/A
	Maximum Temperature :		N/A
	Electric strength test (V) :		N/A
G.5.4.6.3	Tested on the bench - Alternative test method; test time (h) :		N/A
	Electric strength test (V)..... :		N/A
G.5.4.7	Motors with capacitors		N/A
G.5.4.8	Three-phase motors		N/A
G.5.4.9	Series motors		N/A

IEC 62368-1			
Clause	Requirement + Test	Result - Remark	Verdict
	Operating voltage		—
G.6	Wire Insulation		N/A
G.6.1	General	No such parts.	N/A
G.6.2	Solvent-based enamel wiring insulation		N/A
G.7	Mains supply cords		N/A
G.7.1	General requirements	No such parts.	N/A
	Type.....		—
	Rated current (A).....		—
	Cross-sectional area (mm ²), (AWG).....		—
G.7.2	Compliance and test method		N/A
G.7.3	Cord anchorages and strain relief for non-detachable power supply cords		N/A
G.7.3.2	Cord strain relief		N/A
G.7.3.2.1	Requirements		N/A
	Strain relief test force (N)		—
G.7.3.2.2	Strain relief mechanism failure		N/A
G.7.3.2.3	Cord sheath or jacket position, distance (mm)....		—
G.7.3.2.4	Strain relief comprised of polymeric material		N/A
G.7.4	Cord Entry		N/A
G.7.5	Non-detachable cord bend protection		N/A
G.7.5.1	Requirements		N/A
G.7.5.2	Mass (g)		—
	Diameter (m)		—
	Temperature (°C)		—
G.7.6	Supply wiring space		N/A
G.7.6.2	Stranded wire		N/A
G.7.6.2.1	Test with 8 mm strand		N/A
G.8	Varistors		N/A
G.8.1	General requirements	No such parts.	N/A
G.8.2	Safeguard against shock		N/A
G.8.3	Safeguard against fire		N/A
G.8.3.2	Varistor overload test		N/A
G.8.3.3	Temporary overvoltage		N/A
G.9	Integrated Circuit (IC) Current Limiters		P

IEC 62368-1			
Clause	Requirement + Test	Result - Remark	Verdict
G.9.1 a)	Manufacturer defines limit at max. 5A.	Approved component used, see appended table 4.1.2	P
G.9.1 b)	Limiters do not have manual operator or reset		N/A
G.9.1 c)	Supply source does not exceed 250 VA		—
G.9.1 d)	IC limiter output current (max. 5A)		—
G.9.1 e)	Manufacturers' defined drift		—
G.9.2	Test Program 1		N/A
G.9.3	Test Program 2		N/A
G.9.4	Test Program 3		N/A
G.10	Resistors		N/A
G.10.1	General requirements	No such parts.	N/A
G.10.2	Resistor test		N/A
G.10.3	Test for resistors serving as safeguards between the mains and an external circuit consisting of a coaxial cable		N/A
G.10.3.1	General requirements		N/A
G.10.3.2	Voltage surge test		N/A
G.10.3.3	Impulse test		N/A
G.11	Capacitor and RC units		N/A
G.11.1	General requirements	No such parts.	N/A
G.11.2	Conditioning of capacitors and RC units		N/A
G.11.3	Rules for selecting capacitors		N/A
G.12	Optocouplers		N/A
	Optocouplers comply with IEC 60747-5-5:2007 Spacing or Electric Strength Test (specify option and test results).....	No such parts.	N/A
	Type test voltage Vini		—
	Routine test voltage, Vini,b		—
G.13	Printed boards		P
G.13.1	General requirements	See below.	P
G.13.2	Uncoated printed boards	The insulation between conductors on the outer surfaces of an uncoated printed board complied with the minimum clearance and creepage requirements	P
G.13.3	Coated printed boards		N/A
G.13.4	Insulation between conductors on the same inner surface		N/A

IEC 62368-1			
Clause	Requirement + Test	Result - Remark	Verdict
	Compliance with cemented joint requirements (Specify construction)..... :		—
G.13.5	Insulation between conductors on different surfaces		N/A
	Distance through insulation..... :		N/A
	Number of insulation layers (pcs)..... :		—
G.13.6	Tests on coated printed boards		N/A
G.13.6.1	Sample preparation and preliminary inspection		N/A
G.13.6.2a)	Thermal conditioning		N/A
G.13.6.2b)	Electric strength test		N/A
G.13.6.2c)	Abrasion resistance test		N/A
G.14	Coating on components terminals		N/A
G.14.1	Requirements..... :	No such parts.	N/A
G.15	Liquid filled components		N/A
G.15.1	General requirements	No such parts.	N/A
G.15.2	Requirements		N/A
G.15.3	Compliance and test methods		N/A
G.15.3.1	Hydrostatic pressure test		N/A
G.15.3.2	Creep resistance test		N/A
G.15.3.3	Tubing and fittings compatibility test		N/A
G.15.3.4	Vibration test		N/A
G.15.3.5	Thermal cycling test		N/A
G.15.3.6	Force test		N/A
G.15.4	Compliance		N/A
G.16	IC including capacitor discharge function (ICX)		N/A
a)	Humidity treatment in accordance with sc 5.4.8 – 120 hours	No such parts.	N/A
b)	Impulse test using circuit 2 with $U_c =$ to transient voltage..... :		N/A
C1)	Application of ac voltage at 110% of rated voltage for 2.5 minutes		N/A
C2)	Test voltage..... :		—
D1)	10,000 cycles on and off using capacitor with smallest capacitance resistor with largest resistance specified by manufacturer		N/A
D2)	Capacitance..... :		—
D3)	Resistance..... :		—

IEC 62368-1			
Clause	Requirement + Test	Result - Remark	Verdict

H	CRITERIA FOR TELEPHONE RINGING SIGNALS		—
H.1	General	No such parts.	N/A
H.2	Method A		N/A
H.3	Method B		N/A
H.3.1	Ringling signal		N/A
H.3.1.1	Frequency (Hz)		—
H.3.1.2	Voltage (V)		—
H.3.1.3	Cadence; time (s) and voltage (V)		—
H.3.1.4	Single fault current (mA):.....		—
H.3.2	Tripping device and monitoring voltage		N/A
H.3.2.1	Conditions for use of a tripping device or a monitoring voltage complied with		N/A
H.3.2.2	Tripping device		N/A
H.3.2.3	Monitoring voltage (V)		—

J	INSULATED WINDING WIRES FOR USE WITHOUT INTERLEAVED INSULATION		—
	General requirements	No such parts.	N/A

K	SAFETY INTERLOCKS		—
K.1	General requirements	No such parts.	N/A
K.2	Components of safety interlock safeguard mechanism		N/A
K.3	Inadvertent change of operating mode		N/A
K.4	Interlock safeguard override		N/A
K.5	Fail-safe		N/A
	Compliance		N/A
K.6	Mechanically operated safety interlocks		N/A
K.6.1	Endurance requirement		N/A
K.6.2	Compliance and Test method		N/A
K.7	Interlock circuit isolation		N/A
K.7.1	Separation distance for contact gaps & interlock circuit elements (type and circuit location)		N/A
K.7.2	Overload test, Current (A)		N/A
K.7.3	Endurance test		N/A
K.7.4	Electric strength test		N/A

IEC 62368-1			
Clause	Requirement + Test	Result - Remark	Verdict
L	DISCONNECT DEVICES		—
L.1	General requirements	No such parts.	N/A
L.2	Permanently connected equipment		N/A
L.3	Parts that remain energized		N/A
L.4	Single phase equipment		N/A
L.5	Three-phase equipment		N/A
L.6	Switches as disconnect devices		N/A
L.7	Plugs as disconnect devices		N/A
L.8	Multiple power sources		N/A

M	EQUIPMENT CONTAINING BATTERIES AND THEIR PROTECTION CIRCUITS		—
M.1	General requirements	See below.	P
M.2	Safety of batteries and their cells		P
M.2.1	Requirements		P
M.2.2	Compliance and test method (identify method) ... :	See appended table 4.1.2 for RTC battery.	P
M.3	Protection circuits		P
M.3.1	Requirements		P
M.3.2	Tests	Lithium coin battery is protected against charging current by multiple components.	P
	- Overcharging of a rechargeable battery		N/A
	- Unintentional charging of a non-rechargeable battery		P
	- Reverse charging of a rechargeable battery		N/A
	- Excessive discharging rate for any battery		N/A
M.3.3	Compliance	(See appended table annex M)	P
M.4	Additional safeguards for equipment containing secondary lithium battery		N/A
M.4.1	General		N/A
M.4.2	Charging safeguards		N/A
M.4.2.1	Charging operating limits		N/A
M.4.2.2a)	Charging voltage, current and temperature		—
M.4.2.2 b)	Single faults in charging circuitry		—
M.4.3	Fire Enclosure		N/A
M.4.4	Endurance of equipment containing a secondary lithium battery		N/A

IEC 62368-1			
Clause	Requirement + Test	Result - Remark	Verdict
M.4.4.2	Preparation		N/A
M.4.4.3	Drop and charge/discharge function tests		N/A
	Drop		N/A
	Charge		N/A
	Discharge		N/A
M.4.4.4	Charge-discharge cycle test		N/A
M.4.4.5	Result of charge-discharge cycle test		N/A
M.5	Risk of burn due to short circuit during carrying	Not carrying.	N/A
M.5.1	Requirement		N/A
M.5.2	Compliance and Test Method (Test of P.2.3)		N/A
M.6	Prevention of short circuits and protection from other effects of electric current		N/A
M.6.1	Short circuits		N/A
M.6.1.1	General requirements		N/A
M.6.1.2	Test method to simulate an internal fault		N/A
M.6.1.3	Compliance (Specify M.6.1.2 or alternative method)		N/A
M.6.2	Leakage current (mA)		N/A
M.7	Risk of explosion from lead acid and NiCd batteries		N/A
M.7.1	Ventilation preventing explosive gas concentration		N/A
M.7.2	Compliance and test method		N/A
M.8	Protection against internal ignition from external spark sources of lead acid batteries		N/A
M.8.1	General requirements		N/A
M.8.2	Test method		N/A
M.8.2.1	General requirements		N/A
M.8.2.2	Estimation of hypothetical volume V_z (m ³ /s).....		—
M.8.2.3	Correction factors		—
M.8.2.4	Calculation of distance d (mm)		—
M.9	Preventing electrolyte spillage		N/A
M.9.1	Protection from electrolyte spillage		N/A
M.9.2	Tray for preventing electrolyte spillage		N/A
M.10	Instructions to prevent reasonably foreseeable misuse (Determination of compliance: inspection, data review; or abnormal testing)		N/A

IEC 62368-1			
Clause	Requirement + Test	Result - Remark	Verdict
N	ELECTROCHEMICAL POTENTIALS		—
	Metal(s) used	Pollution degree considered.	—

O	MEASUREMENT OF CREEPAGE DISTANCES AND CLEARANCES		—
	Figures O.1 to O.20 of this Annex applied		—

P	SAFEGUARDS AGAINST ENTRY OF FOREIGN OBJECTS AND SPILLAGE OF INTERNAL LIQUIDS		—
P.1	General requirements	See below.	P
P.2.2	Safeguards against entry of foreign object		P
	Location and Dimensions (mm)	Openings did not exceed 5 mm in any dimension or 1 mm in width regardless of length.	—
P.2.3	Safeguard against the consequences of entry of foreign object		N/A
P.2.3.1	Safeguards against the entry of a foreign object	No PIS or no bare conductive parts of ES3 or PS3 circuits in Figure P.3.	N/A
	Openings in transportable equipment	Not transportable equipment.	N/A
	Transportable equipment with metalized plastic parts		N/A
P.2.3.2	Openings in transportable equipment in relation to metallized parts of a barrier or enclosure (identification of supplementary safeguard)		N/A
P.3	Safeguards against spillage of internal liquids	No such parts.	N/A
P.3.1	General requirements		N/A
P.3.2	Determination of spillage consequences		N/A
P.3.3	Spillage safeguards		N/A
P.3.4	Safeguards effectiveness		N/A
P.4	Metallized coatings and adhesive securing parts	No such parts.	N/A
P.4.2 a)	Conditioning testing		N/A
	Tc (°C).....		—
	Tr (°C)		—
	Ta (°C).....		—
P.4.2 b)	Abrasion testing		N/A
P.4.2 c)	Mechanical strength testing		N/A

IEC 62368-1			
Clause	Requirement + Test	Result - Remark	Verdict
Q	CIRCUITS INTENDED FOR INTERCONNECTION WITH BUILDING WIRING		—
Q.1	Limited power sources	See below.	P
Q.1.1 a)	Inherently limited output	RS232 port (CN2)	P
Q.1.1 b)	Impedance limited output	DVI port (MDP3, MDP4)	P
	- Regulating network limited output under normal operating and simulated single fault condition		N/A
Q.1.1 c)	Overcurrent protective device limited output		N/A
Q.1.1 d)	IC current limiter complying with G.9	USB port (CN6)	P
Q.1.2	Compliance and test method	(See appended table Annex Q.1)	P
Q.2	Test for external circuits – paired conductor cable		N/A
	Maximum output current (A)		—
	Current limiting method		—

R	LIMITED SHORT CIRCUIT TEST		—
R.1	General requirements	No such parts.	N/A
R.2	Determination of the overcurrent protective device and circuit		N/A
R.3	Test method Supply voltage (V) and short-circuit current (A).		N/A

S	TESTS FOR RESISTANCE TO HEAT AND FIRE		—
S.1	Flammability test for fire enclosures and fire barrier materials of equipment where the steady state power does not exceed 4 000 W	No such parts.	N/A
	Samples, material		—
	Wall thickness (mm).....		—
	Conditioning (°C).....		—
	Test flame according to IEC 60695-11-5 with conditions as set out		N/A
	- Material not consumed completely		N/A
	- Material extinguishes within 30s		N/A
	- No burning of layer or wrapping tissue		N/A
S.2	Flammability test for fire enclosure and fire barrier integrity		N/A
	Samples, material		—
	Wall thickness (mm).....		—
	Conditioning (°C).....		—

IEC 62368-1			
Clause	Requirement + Test	Result - Remark	Verdict
	Test flame according to IEC 60695-11-5 with conditions as set out		N/A
	Test specimen does not show any additional hole		N/A
S.3	Flammability test for the bottom of a fire enclosure		N/A
	Samples, material		—
	Wall thickness (mm).....		—
	Cheesecloth did not ignite		N/A
S.4	Flammability classification of materials		N/A
S.5	Flammability test for fire enclosure materials of equipment with a steady-state power exceeding 4000 W		N/A
	Samples, material		—
	Wall thickness (mm).....		—
	Conditioning (test condition), (°C).....		—
	Test flame according to IEC 60695-11-20 with conditions as set out		N/A
	After every test specimen was not consumed completely		N/A
	After fifth flame application, flame extinguished within 1 min		N/A

T	MECHANICAL STRENGTH TESTS		—
T.1	General requirements	See below.	P
T.2	Steady force test, 10 N		N/A
T.3	Steady force test, 30 N		N/A
T.4	Steady force test, 100 N		N/A
T.5	Steady force test, 250 N	(See appended table T.5)	P
T.6	Enclosure impact test	(See appended table T.6)	P
	Fall test	See above.	P
	Swing test	See above.	P
T.7	Drop test		N/A
T.8	Stress relief test		N/A
T.9	Impact Test (glass)		N/A
T.9.1	General requirements		N/A
T.9.2	Impact test and compliance		N/A
	Impact energy (J).....		—

IEC 62368-1			
Clause	Requirement + Test	Result - Remark	Verdict
	Height (m)		—
T.10	Glass fragmentation test		N/A
T.11	Test for telescoping or rod antennas		N/A
	Torque value (Nm)		—

U	MECHANICAL STRENGTH OF CATHODE RAY TUBES (CRT) AND PROTECTION AGAINST THE EFFECTS OF IMPLOSION		—
U.1	General requirements	No such parts.	N/A
U.2	Compliance and test method for non-intrinsically protected CRTs		N/A
U.3	Protective Screen.....		N/A

V	DETERMINATION OF ACCESSIBLE PARTS (FINGERS, PROBES AND WEDGES)		—
V.1	Accessible parts of equipment	The surfaces and openings are evaluated by the test probe of Figure V.1 and V.2	P
V.2	Accessible part criterion	No live parts can be accessible.	P

IEC 62368-1			
Clause	Requirement + Test	Result - Remark	Verdict

4.1.2	TABLE: List of critical components					P
Object / part No.	Manufacturer/ trademark	Type / model	Technical data	Standard	Mark(s) of conformity ¹	
Enclosure material	--	--	SECC on steel; minimum 0.8 mm thickness.	--	--	
Solid State Drive (SSD) (optional)	Interchangeable	Interchangeable	2.5 inch, rated 5 V d.c., 1.6 A max.	--	--	
All PCBs material	Interchangeable	Interchangeable	V-1 or better; min. 105 °C min.	UL 796	UL*	
Polyswitch (F3, F4) (DVI port protector)	Polytronics Technology Corp.	SMD0805P175S LR	PTC type; Vmax= 6 V d.c.; Ih= 1.75 A; It= 3.5 A	IEC/EN 60730-1: 2000 Tested to clauses 15, 17, J15 and J17; UL 1434	TUV (R 50099121); UL* (E201431)	
IC Current Limiter (U19) (USB 2.0 port protector)	TEXAS INSTRUMENTS INC	TPS2561DRCT	Input Voltage: 2.5-6.5 Vdc, Output Continuous Rating: 2.6 A, Output Current Limit: 3.2 A	IEC 60950- 1:2005/AMD2:20 13	CB (US- 25240-UL)	
Lithium coin battery (BAT1)	VIC-DAWN ENTERPRISE CO LTD	BR2032	Max abnormal charging current 10 mA	UL 1642	UL* (MH20550)	
(Alternate)	JL WORLD CO LTD	BR2032	Max abnormal charging current 10 mA	UL 1642	UL* (MH20926)	
(Alternate)	DOUBLE BEST CO LTD	BR2032	Max abnormal charging current 10 mA	UL 1642	UL* (MH46388)	
(Alternate)	VIC-DAWN ENTERPRISE CO LTD	BR2032	Max abnormal charging current 10 mA	UL 1642	UL* (MH20550)	
(Alternate)	PANASONIC CORPORATION, PANASONIC CORPORATION OF NORTH AMERICA	BR2032*, BR- 2032*	Max abnormal charging current 10 mA	UL 1642	UL* (MH12210)	

IEC 62368-1					
Clause	Requirement + Test			Result - Remark	Verdict
(Alternate)	FUJI BATTERIES INC	BR2032	Max abnormal charging current 10 mA	UL 1642	UL* (MH64203)
(Alternate)	Interchangeable	BR2032 series	Max. abnormal charging current 10 mA.	UL 1642	UL*
(Alternate)	Interchangeable	CR2032 series	Max abnormal charging current 10 mA	UL 1642	UL*
Supplementary information: 1) Provided evidence ensures the agreed level of compliance. See OD-2039. 2) Description line content is optional. Main line description needs to clearly detail the component used for testing * License available upon request.					

4.8.4, 4.8.5	TABLE: Lithium coin/button cell batteries mechanical tests			N/A
(The following mechanical tests are conducted in the sequence noted.)				
4.8.4.2	TABLE: Stress Relief test			—
	Part	Material	Oven Temperature (°C)	Comments
4.8.4.3	TABLE: Battery replacement test			—
	Battery part no.:	No batteries.		—
	Battery Installation/withdrawal	Battery Installation/Removal Cycle	Comments	
		1		
		2		
		3		
		4		
		5		
		6		
		8		
		9		
		10		
4.8.4.4	TABLE: Drop test			—
	Impact Area	Drop Distance	Drop No.	Observations
			1	
			2	

IEC 62368-1			
Clause	Requirement + Test	Result - Remark	Verdict
4.8.4, 4.8.5	TABLE: Lithium coin/button cell batteries mechanical tests		N/A
(The following mechanical tests are conducted in the sequence noted.)			
		3	
4.8.4.5	TABLE: Impact		—
Impacts per surface	Surface tested	Impact energy (Nm)	Comments
4.8.4.6	TABLE: Crush test		—
Test position	Surface tested	Crushing Force (N)	Duration force applied (s)
Supplementary information:			

4.8.5	TABLE: Lithium coin/button cell batteries mechanical test result		N/A
Test position	Surface tested	Force (N)	Duration force applied (s)
Supplementary information:			

IEC 62368-1			
Clause	Requirement + Test	Result - Remark	Verdict

5.2	Table: Classification of electrical energy sources	N/A	
------------	---	-----	--

5.2.2.2 – Steady State Voltage and Current conditions

No.	Supply Voltage	Location (e.g. circuit designation)	Test conditions	Parameters			ES Class
				U (dc)	I (Apk or Arms)	Hz	
			Normal				
			Abnormal				
			Single fault – SC/OC				

5.2.2.3 - Capacitance Limits

No.	Supply Voltage	Location (e.g. circuit designation)	Test conditions	Parameters		ES Class
				Capacitance, nF	Upk (V)	
			Normal			
			Abnormal			
			Single fault – SC/OC			

5.2.2.4 - Single Pulses

No.	Supply Voltage	Location (e.g. circuit designation)	Test conditions	Parameters			ES Class
				Duration (ms)	Upk (V)	Ipk (mA)	
			Normal				
			Abnormal				
			Single fault – SC/OC				

5.2.2.5 - Repetitive Pulses

No.	Supply Voltage	Location (e.g. circuit designation)	Test conditions	Parameters			ES Class
				Off time (ms)	Upk (V)	Ipk (mA)	
			Normal				
			Abnormal				
			Single fault – SC/OC				

Test Conditions:
 Normal –
 Abnormal -
 Supplementary information: SC=Short Circuit, OC=Short Circuit

IEC 62368-1							
Clause	Requirement + Test			Result - Remark		Verdict	
5.4.1.4, 6.3.2, 9.0, B.2.6	TABLE: Temperature measurements						P
	Supply voltage (V)	DC 18	DC 36			—	
	Ambient T _{min} (°C)	--				—	
	Ambient T _{max} (°C)	--				—	
	T _{ma} (°C)	See below.				—	
Maximum measured temperature T of part/at:		T (°C)			Allowed T _{max} (°C)		
DC converter body		96.3	102.1			105	
Capacitance		75.7	79.3			105	
Main board : PCB near CPU1		95.5	98.9			105	
Main board : BAT1		82.1	85.8			--	
Main board : PCB near U12		86.0	90.0			105	
Connect board : PCB near U1		86.8	90.3			105	
I/O board : PCB near U14		88.3	91.7			105	
DATA board : PCB near U885		85.6	88.9			105	
SSD		79.1	82.7			--	
T _{ma}		55.0	55.0			--	
T _{amb}		24.5	23.9			--	
Touch temperature for accessible parts: (re-calculated to 25 degree C from actual ambient respectively)							
Control button		38.3	40.8			4) 77 (TS1)	
Metal enclosure outside		42.3	45.1			4) 60 (TS1)	
Supplementary information:							
1) The temperatures were measured under worst case normal mode and at voltages as described above.							
2) With a maximum ambient temperature of +55 °C as declared by the manufacturer.							
3) All values for T (°C) are re-calculated from actual ambient.							
4) Considered as > 1 s and < 10 s.							
Temperature T of winding:	t ₁ (°C)	R ₁ (Ω)	t ₂ (°C)	R ₂ (Ω)	T (°C)	Allowed T _{max} (°C)	Insulation class
--							
Supplementary information:							
Supplementary information:							
Note 1: T _{ma} should be considered as directed by applicable requirement							
Note 2: T _{ma} is not included in assessment of Touch Temperatures (Clause 9)							

IEC 62368-1			
Clause	Requirement + Test	Result - Remark	Verdict

5.4.1.10.2	TABLE: Vicat softening temperature of thermoplastics		N/A
Penetration (mm) :			—
Object/ Part No./Material	Manufacturer/t rademark	T softening (°C)	
Supplementary information:			

5.4.1.10.3	TABLE: Ball pressure test of thermoplastics			N/A
Allowed impression diameter (mm) :	≤ 2 mm			—
Object/Part No./Material	Manufacturer/trademark	Test temperature (°C)	Impression diameter (mm)	
Supplementary information:				

5.4.2.2, 5.4.2.4 and 5.4.3	TABLE: Minimum Clearances/Creepage distance							N/A
Clearance (cl) and creepage distance (cr) at/of/between:	Up (V)	U r.m.s. (V)	Frequenc y (kHz) ¹	Required cl (mm)	cl (mm) ²	Required ³ cr (mm)	cr (mm)	
Functional:								
Basic/ supplementary:								
Reinforced:								
Supplementary information:								
Note 1: Only for frequency above 30 kHz								
Note 2: See table 5.4.2.4 if this is based on electric strength test								
Note 3: Provide Material Group								

5.4.2.3	TABLE: Minimum Clearances distances using required withstand voltage				N/A
	Overvoltage Category (OV):				
	Pollution Degree:				
Clearance distanced between:	Required withstand voltage	Required cl (mm)	Measured cl (mm)		
Supplementary information:					

IEC 62368-1			
Clause	Requirement + Test	Result - Remark	Verdict

5.4.2.4	TABLE: Clearances based on electric strength test			N/A
Test voltage applied between:	Required cl (mm)	Test voltage (kV) peak/ r.m.s. / d.c.	Breakdown Yes / No	
Supplementary information:				

5.4.4.2, 5.4.4.5 c) 5.4.4.9	TABLE: Distance through insulation measurements					N/A
Distance through insulation di at/of:	Peak voltage (V)	Frequency (kHz)	Material	Required DTI (mm)	DTI (mm)	
Supplementary information:						

5.4.9	TABLE: Electric strength tests				N/A
Test voltage applied between:	Voltage shape (AC, DC)	Test voltage (V)	Breakdown Yes / No		
Functional:					
--	--	--	--		
Basic/supplementary:					
--	--	--	--		
Reinforced:					
--	--	--	--		
Routine Tests:					
--	--	--	--		
Supplementary information:					

5.5.2.2	TABLE: Stored discharge on capacitors					N/A
Supply Voltage (V), Hz	Test Location	Operating Condition (N, S)	Switch position On or off	Measured Voltage (after 2 seconds)	ES Classification	
Supplementary information:						

IEC 62368-1			
Clause	Requirement + Test	Result - Remark	Verdict

X-capacitors installed for testing are:
 bleeding resistor rating:
 ICX:
 Notes:
 A. Test Location:
 Phase to Neutral; Phase to Phase; Phase to Earth; and/or Neutral to Earth
 B. Operating condition abbreviations:
 N – Normal operating condition (e.g., normal operation, or open fuse); S –Single fault condition

5.6.6.2	TABLE: Resistance of protective conductors and terminations	N/A		
Accessible part	Test current (A)	Duration (min)	Voltage drop (V)	Resistance (Ω)
Supplementary information:				

5.7.2.2, 5.7.4	TABLE: Earthed accessible conductive part	N/A
Supply voltage		—
Location	Test conditions specified in 6.1 of IEC 60990 or Fault Condition No in IEC 60990 clause 6.2.2.1 through 6.2.2.8, except for 6.2.2.7	Touch current (mA)
Line/Neutral to metal enclosure.	1	--
	2*	--
	3	--
	4	--
	5	--
	6	--
	8	--
Supplementary Information:		
Notes: [1] Supply voltage is the anticipated maximum Touch Voltage [2] Earthed neutral conductor [Voltage differences less than 1% or more] [3] Specify method used for measurement as described in IEC 60990 sub-clause 4.3 [4] IEC60990, sub-clause 6.2.2.7, Fault 7 not applicable. [5] (*) IEC60990, sub-clause 6.2.2.2 is not applicable if switch or disconnect device (e.g., appliance coupler) provided.		

IEC 62368-1			
Clause	Requirement + Test	Result - Remark	Verdict

6.2.2	Table: Electrical power sources (PS) measurements for classification					N/A
Source	Description	Measurement	Max Power after 3 s	Max Power after 5 s*)	PS Classification	
A		Power (W) :				
		V _A (V) :				
		I _A (A) :				
B		Power (W) :				
		V _A (V) :				
		I _A (A) :				
C		Power (W) :				
		V _A (V) :				
		I _A (A) :				
D		Power (W) :				
		V _A (V) :				
		I _A (A) :				
Supplementary Information:						
(*) Measurement taken only when limits at 3 seconds exceed PS1 limits						

6.2.3.1	Table: Determination of Potential Ignition Sources (Arcing PIS)				N/A
Location	Open circuit voltage After 3 s (V _p)	Measured r.m.s current (I _{rms})	Calculated value (V _p x I _{rms})	Arcing PIS? Yes / No	
Supplementary information:					
An Arcing PIS requires a minimum of 50 V (peak) a.c. or d.c. An Arcing PIS is established when the product of the open circuit voltage (V _p) and normal operating condition rms current (I _{rms}) is greater than 15.					

6.2.3.2	Table: Determination of Potential Ignition Sources (Resistive PIS)				N/A
Circuit Location (x-y)	Operating Condition (Normal / Describe Single Fault)	Measured wattage or VA During first 30 s (W / VA)	Measured wattage or VA After 30 s (W / VA)	Protective Circuit, Regulator, or PTC Operated? Yes / No (Comment)	Resistive PIS? Yes/No
Supplementary Information:					

IEC 62368-1			
Clause	Requirement + Test	Result - Remark	Verdict

A combination of voltmeter, VA and ammeter IA may be used instead of a wattmeter.
 If a separate voltmeter and ammeter are used, the product of (VA x IA) is used to determine Resistive PIS classification.
 A Resistive PIS: (a) dissipates more than 15 W, measured after 30 s of normal operation, or (b) under single fault conditions has either a power exceeding 100 W measured immediately after the introduction of the fault if electronic circuits, regulators or PTC devices are used, or has an available power exceeding 15 W measured 30 s after introduction of the fault.

8.5.5	TABLE: High Pressure Lamp	N/A
Description	Values	Energy Source Classification
Lamp type		—
Manufacturer		—
Cat no.		—
Pressure (cold) (MPa).....		MS_
Pressure (operating) (MPa).....		MS_
Operating time (minutes)		—
Explosion method		—
Max particle length escaping enclosure (mm) .:		MS_
Max particle length beyond 1 m (mm).....		MS_
Overall result		
Supplementary information:		

B.2.5	TABLE: Input test								P
U (V)	Hz	I (A)	I rated (A)	P (W)	P rated (W)	Fuse No	I fuse (A)	Condition/status	
DC 18	--	4.05	20	72.9	--	--	--	Maximum normal load	
DC 36	--	2.01	20	72.4	--	--	--	Maximum normal load	
Supplementary information:									
Equipment may be have rated current or rated power or both. Both should be measured									

IEC 62368-1			
Clause	Requirement + Test	Result - Remark	Verdict

B.3	TABLE: Abnormal operating condition tests							P
Ambient temperature (°C) :						See below		—
Power source for EUT: Manufacturer, model/type, output rating :						--		—
Component No.	Abnormal Condition	Supply voltage, (V)	Test time (ms)	Fuse no.	Fuse current, (A)	T-couple	Temp. (°C)	Observation
USB 2.0 port	Overload	DC 36	2 hr 55 min	--	--	1. Ambient	23.6	PoE output 0.5 A normal operation, output 0.6 A shut down, other function normal operation, no fire or flame hazards occurred during and after the test.
						2. DC converter body	71.4	
						3. Metal enclosure outside near T3	43.7	
Supplementary information: Test table is provided to record abnormal and fault conditions for all applicable energy sources including Thermal burn injury. Column "Abnormal/Fault." Specify if test condition by indicating "Abnormal" then the condition for a Clause B.3 test or "Single Fault" then the condition for Clause B.4.								

B.4	TABLE: Fault condition tests							P
Ambient temperature (°C) :						See below		—
Power source for EUT: Manufacturer, model/type, output rating :						--		—
Component No.	Fault Condition	Supply voltage, (V)	Test time (ms)	Fuse no.	Fuse current, (A)	T-couple	Temp. (°C)	Observation
C592	SC	DC 36	10 min	--	--	--	--	EUT shut down, no fire or flame hazards occurred during and after the test.
Supplementary information: SC=Short circuit, OC=Open circuit NCD=No component damaged, NH=No hazard								

Annex M.3	TABLE: Batteries		P
The tests of Annex M are applicable only when appropriate battery data is not available			
Is it possible to install the battery in a reverse polarity position? :		No	
Non-rechargeable batteries		Rechargeable batteries	

IEC 62368-1			
Clause	Requirement + Test		Result - Remark

	Discharging		Un-intentional charging	Charging		Discharging		Reversed charging	
	Meas. current	Manuf. Specs.		Meas. current	Manuf. Specs.	Meas. current	Manuf. Specs.	Meas. current	Manuf. Specs.
Max. current during normal condition	--	--	0 mA	--	--	--	--	--	--
Max. current during fault condition R113 short circuit	--	--	0 mA	--	--	--	--	--	--
Max. current during fault condition D2 (1 – 3) short circuit	--	--	3 mA	--	--	--	--	--	--

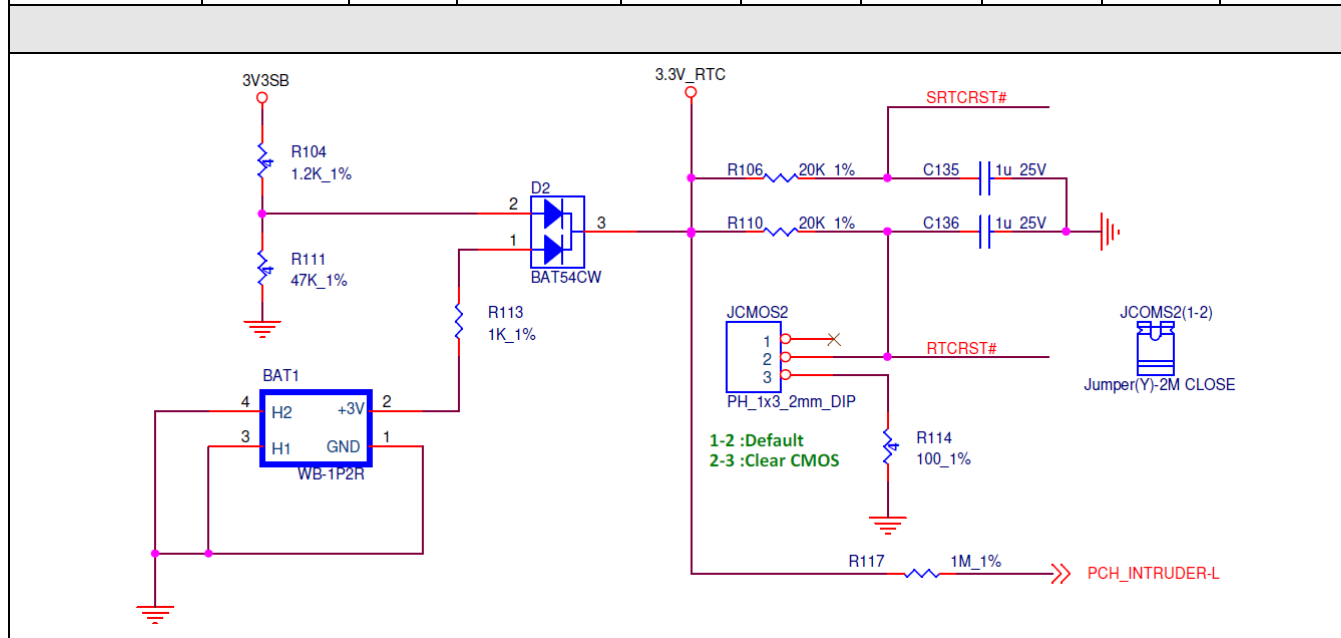

Test results:		Verdict
- Chemical leaks	No chemical leaks.	P
- Explosion of the battery	No explosion.	P
- Emission of flame or expulsion of molten metal	No emission of flame or expulsion of molten metal.	P
- Electric strength tests of equipment after completion of tests	--	N/A
Supplementary information:		

IEC 62368-1					
Clause	Requirement + Test			Result - Remark	Verdict
Annex M.4	Table: Additional safeguards for equipment containing secondary lithium batteries				N/A
Battery/Cell No.	Test conditions	Measurements			Observation
		U	I (A)	Temp (C)	
	Normal				
	Abnormal				
	Single fault –SC/OC				
	Normal				
	Abnormal				
	Single fault – SC/OC				
Supplementary Information:					
Battery identification	Charging at T _{lowest} (°C)	Observation	Charging at T _{highest} (°C)	Observation	
Supplementary Information:					

Annex Q.1	TABLE: Circuits intended for interconnection with building wiring (LPS)					P
Note: Measured UOC (V) with all load circuits disconnected: See below.						
Output Circuit	Components	U _{oc} (V)	I _{sc} (A)		S (VA)	
			Meas.	Limit	Meas.	Limit
USB 2.0 port (CN6), pin 1 to GND. (Protected by U19)	Normal condition	5.09	0.57	≤8	2.31	≤100
USB 2.0 port (CN6), pin 6 to GND. (Protected by U19)	Normal condition	5.09	0.57	≤8	2.31	≤100

IEC 62368-1						
Clause	Requirement + Test			Result - Remark		Verdict
USB 2.0 port (CN6), other pins to GND.	Normal condition	0	0	≤8	0	≤100
USB 2.0 port (CN7), pin 1 to GND. (Protected by U19)	Normal condition	5.09	0.49	≤8	2.18	≤100
USB 2.0 port (CN7), pin 6 to GND. (Protected by U19)	Normal condition	5.09	0.49	≤8	2.20	≤100
USB 2.0 port (CN7), other pins to GND.	Normal condition	0	0	≤8	0	≤100
DVI port (MDP3), pin 20 to GND. (Protected by F3)	Normal condition	3.23	1.18	≤8	1.23	≤100
DVI port (MDP3), other pins to GND.	Normal condition	0	0	≤8	0	≤100
DVI port (MDP4), pin 2 to GND.	Normal condition	2.29	0	≤8	0	≤100
DVI port (MDP4), pin 20 to GND. (Protected by F4)	Normal condition	1.21	0.29	≤8	0.26	≤100
DVI port (MDP4), other pins to GND.	Normal condition	0	0	≤8	0	≤100
RS232 port (CN2), all pins to GND.	Normal condition	0	0	≤8	0	≤100

IEC 62368-1			
Clause	Requirement + Test	Result - Remark	Verdict

Supplementary Information:
SC=Short circuit, OC=Open circuit

T.2, T.3, T.4, T.5	TABLE: Steady force test					P
Part/Location	Material	Thickness (mm)	Force (N)	Test Duration (sec)	Observation	
Enclosure/ Top	See appended table 4.1.2	See appended table 4.1.2	250	5	1)	
Enclosure/ Side	See appended table 4.1.2	See appended table 4.1.2	250	5	1)	
Enclosure/ Bottom	See appended table 4.1.2	See appended table 4.1.2	250	5	1)	

Supplementary information:
1) No cracking, all safeguards remain effective.

T.6, T.9	TABLE: Impact tests				P
Part/Location	Material	Thickness (mm)	Vertical distance (mm)	Observation	
Enclosure/ Top	See appended table 4.1.2	See appended table 4.1.2	1300	1)	
Enclosure/ Side	See appended table 4.1.2	See appended table 4.1.2	1300	1)	
Enclosure/ Bottom	See appended table 4.1.2	See appended table 4.1.2	1300	1)	

Supplementary information:
1) No cracking, all safeguards remain effective.

T.7	TABLE: Drop tests				N/A
Part/Location	Material	Thickness (mm)	Drop Height (mm)	Observation	

Supplementary information:

IEC 62368-1			
Clause	Requirement + Test	Result - Remark	Verdict

T.8	TABLE: Stress relief test					N/A
Part/Location	Material	Thickness (mm)	Oven Temperature (°C)	Duration (h)	Observation	

Supplementary information:

IEC 62368-1			
Clause	Requirement + Test	Result - Remark	Verdict

List of test equipment used:

	ID Number	Manufacture	Description	Model No.	Serial No.	Specification / Range
X	CR08	YOKOGAWA	Mobile Recorder	MV230-1-2-1-1D	S5E805255	K Type, 0 to 1000°C
X	CR25	Lascar	Temperature & Humidity Data Logger	EL-GFX-2	N/A	a) 10 - 40°C ; b) 50 - 80% RH
X	EL12	PRODIGIT	DC Electronic Load	3311F	91000FC0072	0-60Vdc, 0-60A, 0-300W
X	MF03	ALGOL	Handy Force Gauge	HF-100	HF-112762	Push Pull 0-1000N
X	MI02	TESTING	Steel Ball	N/A	MI02	IEC 61032 Figure 5 by a) 500g ; b) 50mm
X	ML02	NIGATA SEIKI	Protractor	LM-90	ML02	0-90°
X	MT03	ARCH	Steel Rule	1000mm	A01150	0-1000mm
X	TM05	CASIO	STOPWATCH	HS-3	605Q13R	9:59'59.99"
X	TP10	N/A	Test Pin (Test probe D)	N/A	TP10	IEC 61032 Figure 4 ; 1.0Φ×100mm
X	TP12	TESTING	Test Finger (Test probe B)	N/A	TP12	IEC 61032 Figure 2 ; 12Φx 80mm

-- End of TEST REPORT --

IEC62368_1D - ATTACHMENT			
Clause	Requirement + Test	Result - Remark	Verdict

Attachment 1 European Group Differences And National Differences

ATTACHMENT TO TEST REPORT IEC 62368-1 EUROPEAN GROUP DIFFERENCES AND NATIONAL DIFFERENCES (Audio/video, information and communication technology equipment - Part 1: Safety requirements)						
Differences according to: EN 62368-1:2014+A11:2017						
Attachment Form No.: EU_GD_IEC62368_1D_II						
Attachment Originator: Nemko AS						
Master Attachment: Date 2021-02-04						
Copyright © 2021 IEC System for Conformity Testing and Certification of Electrical Equipment (IECEE), Geneva, Switzerland. All rights reserved.						
	CENELEC COMMON MODIFICATIONS (EN)					—
	Clauses, subclauses, notes, tables, figures and annexes which are additional to those in IEC 62368-1:2014 are prefixed “Z”.					—
CONTENTS	Add the following annexes: Annex ZA (normative) Normative references to international publications with their corresponding European publications Annex ZB (normative) Special national conditions Annex ZC (informative) A-deviations Annex ZD (informative) IEC and CENELEC code designations for flexible cords					—
	Delete all the “country” notes in the reference document (IEC 62368-1:2014) according to the following list:					—
	0.2.1	Note	1	Note 3	4.1.15	Note
	4.7.3	Note 1 and 2	5.2.2.2	Note	5.4.2.3.2.2 Table 13	Note c
	5.4.2.3.2.4	Note 1 and 3	5.4.2.5	Note 2	5.4.5.1	Note
	5.5.2.1	Note	5.5.6	Note	5.6.4.2.1	Note 2 and 3
	5.7.5	Note	5.7.6.1	Note 1 and 2	10.2.1 Table 39	Note 2, 3 and 4
	10.5.3	Note 2	10.6.2.1	Note 3	F.3.3.6	Note 3
	For special national conditions, see Annex ZB.					—

IEC62368_1D - ATTACHMENT			
Clause	Requirement + Test	Result - Remark	Verdict
1	<p>Add the following note:</p> <p>NOTE Z1 The use of certain substances in electrical and electronic equipment is restricted within the EU: see Directive 2011/65/EU.</p>	Added.	P
4.Z1	<p>Add the following new subclause after 4.9:</p> <p>To protect against excessive current, short-circuits and earth faults in circuits connected to an a.c. mains, protective devices shall be included either as integral parts of the equipment or as parts of the building installation, subject to the following, a), b) and c):</p> <p>a) except as detailed in b) and c), protective devices necessary to comply with the requirements of B.3.1 and B.4 shall be included as parts of the equipment;</p> <p>b) for components in series with the mains input to the equipment such as the supply cord, appliance coupler, r.f.i. filter and switch, short-circuit and earth fault protection may be provided by protective devices in the building installation;</p> <p>c) it is permitted for pluggable equipment type B or permanently connected equipment, to rely on dedicated overcurrent and short-circuit protection in the building installation, provided that the means of protection, e.g. fuses or circuit breakers, is fully specified in the installation instructions.</p> <p>If reliance is placed on protection in the building installation, the installation instructions shall so state, except that for pluggable equipment type A the building installation shall be regarded as providing protection in accordance with the rating of the wall socket outlet.</p>	This requirement doesn't applicable for a Class III equipment.	N/A
5.4.2.3.2.4	<p>Add the following to the end of this subclause:</p> <p>The requirement for interconnection with external circuit is in addition given in EN 50491-3:2009.</p>	No external circuits.	N/A
10.2.1	<p>Add the following to ^{c)} and ^{d)} in table 39:</p> <p>For additional requirements, see 10.5.1.</p>	No such parts.	N/A

IEC62368_1D - ATTACHMENT

Clause	Requirement + Test	Result - Remark	Verdict
--------	--------------------	-----------------	---------

10.5.1	<p>Add the following after the first paragraph: <i>For RS 1 compliance is checked by measurement under the following conditions:</i></p> <p><i>In addition to the normal operating conditions, all controls adjustable from the outside by hand, by any object such as a tool or a coin, and those internal adjustments or presets which are not locked in a reliable manner, are adjusted so as to give maximum radiation whilst maintaining an intelligible picture for 1 h, at the end of which the measurement is made.</i></p> <p>NOTE Z1 Soldered joints and paint lockings are examples of adequate locking.</p> <p><i>The dose-rate is determined by means of a radiation monitor with an effective area of 10 cm², at any point 10 cm from the outer surface of the apparatus.</i></p> <p><i>Moreover, the measurement shall be made under fault conditions causing an increase of the high-voltage, provided an intelligible picture is maintained for 1 h, at the end of which the measurement is made.</i></p> <p><i>For RS1, the dose-rate shall not exceed 1 μSv/h taking account of the background level.</i></p> <p>NOTE Z2 These values appear in Directive 96/29/Euratom of 13 May 1996.</p>	No such parts.	N/A
10.6.1	<p>Add the following paragraph to the end of the subclause: EN 71-1:2011, 4.20 and the related tests methods and measurement distances apply.</p>	No such parts.	N/A
10.Z1	<p>Add the following new subclause after 10.6.5. 10.Z1 Non-ionizing radiation from radio frequencies in the range 0 to 300 GHz</p> <p>The amount of non-ionizing radiation is regulated by European Council Recommendation 1999/519/EC of 12 July 1999 on the limitation of exposure of the general public to electromagnetic fields (0 Hz to 300 GHz).</p> <p>For intentional radiators, ICNIRP guidelines should be taken into account for Limiting Exposure to Time-Varying Electric, Magnetic, and Electromagnetic Fields (up to 300 GHz). For hand-held and body-mounted devices, attention is drawn to EN 50360 and EN 50566</p>	No non-ionizing radiation.	N/A
G.7.1	<p>Add the following note: NOTE Z1 The harmonized code designations corresponding to the IEC cord types are given in Annex ZD.</p>		N/A

IEC62368_1D - ATTACHMENT			
Clause	Requirement + Test	Result - Remark	Verdict
Bibliography	<p>Add the following standards:</p> <p>Add the following notes for the standards indicated:</p> <p>IEC 60130-9 NOTE Harmonized as EN 60130-9.</p> <p>IEC 60269-2 NOTE Harmonized as HD 60269-2.</p> <p>IEC 60309-1 NOTE Harmonized as EN 60309-1.</p> <p>IEC 60364 NOTE some parts harmonized in HD 384/HD 60364 series.</p> <p>IEC 60601-2-4 NOTE Harmonized as EN 60601-2-4.</p> <p>IEC 60664-5 NOTE Harmonized as EN 60664-5.</p> <p>IEC 61032:1997 NOTE Harmonized as EN 61032:1998 (not modified).</p> <p>IEC 61508-1 NOTE Harmonized as EN 61508-1.</p> <p>IEC 61558-2-1 NOTE Harmonized as EN 61558-2-1.</p> <p>IEC 61558-2-4 NOTE Harmonized as EN 61558-2-4.</p> <p>IEC 61558-2-6 NOTE Harmonized as EN 61558-2-6.</p> <p>IEC 61643-1 NOTE Harmonized as EN 61643-1.</p> <p>IEC 61643-21 NOTE Harmonized as EN 61643-21.</p> <p>IEC 61643-311 NOTE Harmonized as EN 61643-311.</p> <p>IEC 61643-321 NOTE Harmonized as EN 61643-321.</p> <p>IEC 61643-331 NOTE Harmonized as EN 61643-331.</p>		N/A
ZB	ANNEX ZB, SPECIAL NATIONAL CONDITIONS (EN)		—
4.1.15	<p>Denmark, Finland, Norway and Sweden</p> <p>To the end of the subclause the following is added:</p> <p>Class I pluggable equipment type A intended for connection to other equipment or a network shall, if safety relies on connection to reliable earthing or if surge suppressors are connected between the network terminals and accessible parts, have a marking stating that the equipment shall be connected to an earthed mains socket-outlet.</p> <p>The marking text in the applicable countries shall be as follows:</p> <p>In Denmark: "Apparatets stikprop skal tilsluttes en stikkontakt med jord som giver forbindelse til stikproppens jord."</p> <p>In Finland: "Laite on liitettävä suojakoskettimilla varustettuun pistorasiaan"</p> <p>In Norway: "Apparatet må tilkoples jordet stikkontakt"</p> <p>In Sweden: "Apparaten skall anslutas till jordat uttag"</p>	Shall be checked when marketing into these countries.	N/A

IEC62368_1D - ATTACHMENT			
Clause	Requirement + Test	Result - Remark	Verdict
4.7.3	<p>United Kingdom</p> <p>To the end of the subclause the following is added: The torque test is performed using a socket-outlet complying with BS 1363, and the plug part shall be assessed to the relevant clauses of BS 1363. Also see Annex G.4.2 of this annex</p>		N/A
5.2.2.2	<p>Denmark</p> <p>After the 2nd paragraph add the following: A warning (marking safeguard) for high touch current is required if the touch current exceeds the limits of 3,5 mA a.c. or 10 mA d.c.</p>		N/A

IEC62368_1D - ATTACHMENT			
Clause	Requirement + Test	Result - Remark	Verdict
5.4.11.1 and Annex G	<p>Finland and Sweden</p> <p>To the end of the subclause the following is added: For separation of the telecommunication network from earth the following is applicable: If this insulation is solid, including insulation forming part of a component, it shall at least consist of either</p> <ul style="list-style-type: none"> • two layers of thin sheet material, each of which shall pass the electric strength test below, or • one layer having a distance through insulation of at least 0,4 mm, which shall pass the electric strength test below. <p>If this insulation forms part of a semiconductor component (e.g. an optocoupler), there is no distance through insulation requirement for the insulation consisting of an insulating compound completely filling the casing, so that clearances and creepage distances do not exist, if the component passes the electric strength test in accordance with the compliance clause below and in addition</p> <ul style="list-style-type: none"> • passes the tests and inspection criteria of 5.4.8 with an electric strength test of 1,5 kV multiplied by 1,6 (the electric strength test of 5.4.9 shall be performed using 1,5 kV), and • is subject to routine testing for electric strength during manufacturing, using a test voltage of 1,5kV. <p>It is permitted to bridge this insulation with a capacitor complying with EN 60384-14:2005, subclass Y2.</p> <p>A capacitor classified Y3 according to EN 60384-14:2005, may bridge this insulation under the following conditions:</p> <ul style="list-style-type: none"> • the insulation requirements are satisfied by having a capacitor classified Y3 as defined by EN 60384-14, which in addition to the Y3 testing, is tested with an impulse test of 2,5 kV defined in 5.4.11; • the additional testing shall be performed on all the test specimens as described in EN 60384-14; <p>the impulse test of 2,5 kV is to be performed before the endurance test in EN 60384-14, in the sequence of tests as described in EN 60384-14.</p>	No external circuits.	N/A
5.5.2.1	<p>Norway</p> <p>After the 3rd paragraph the following is added: Due to the IT power system used, capacitors are required to be rated for the applicable line-to-line voltage (230 V).</p>	No used.	N/A

IEC62368_1D - ATTACHMENT			
Clause	Requirement + Test	Result - Remark	Verdict
5.5.6	<p>Finland, Norway and Sweden</p> <p>To the end of the subclause the following is added: Resistors used as basic safeguard or bridging basic insulation in class I pluggable equipment type A shall comply with G.10.1 and the test of G.10.2.</p>	No such parts.	N/A
5.6.1	<p>Denmark</p> <p>Add to the end of the subclause</p> <p>Due to many existing installations where the socket-outlets can be protected with fuses with higher rating than the rating of the socket-outlets the protection for pluggable equipment type A shall be an integral part of the equipment.</p> <p><i>Justification:</i> In Denmark an existing 13 A socket outlet can be protected by a 20 A fuse.</p>	No such parts.	N/A
5.6.4.2.1	<p>Ireland and United Kingdom</p> <p>After the indent for pluggable equipment type A, the following is added:</p> <p>– the protective current rating is taken to be 13 A, this being the largest rating of fuse used in the mains plug.</p>	No such parts.	N/A
5.6.5.1	<p>To the second paragraph the following is added:</p> <p>The range of conductor sizes of flexible cords to be accepted by terminals for equipment with a rated current over 10 A and up to and including 13 A is: 1,25 mm² to 1,5 mm² in cross-sectional area.</p>	No such parts.	N/A
5.7.5	<p>Denmark</p> <p>To the end of the subclause the following is added:</p> <p>The installation instruction shall be affixed to the equipment if the protective conductor current exceeds the limits of 3,5 mA a.c. or 10 mA d.c.</p>		N/A

IEC62368_1D - ATTACHMENT			
Clause	Requirement + Test	Result - Remark	Verdict
5.7.6.1	<p>Norway and Sweden</p> <p>To the end of the subclause the following is added: The screen of the television distribution system is normally not earthed at the entrance of the building and there is normally no equipotential bonding system within the building. Therefore the protective earthing of the building installation needs to be isolated from the screen of a cable distribution system.</p> <p>It is however accepted to provide the insulation external to the equipment by an adapter or an interconnection cable with galvanic isolator, which may be provided by a retailer, for example.</p> <p>The user manual shall then have the following or similar information in Norwegian and Swedish language respectively, depending on in what country the equipment is intended to be used in: "Apparatus connected to the protective earthing of the building installation through the mains connection or through other apparatus with a connection to protective earthing – and to a television distribution system using coaxial cable, may in some circumstances create a fire hazard. Connection to a television distribution system therefore has to be provided through a device providing electrical isolation below a certain frequency range (galvanic isolator, see EN 60728-11)"</p> <p>NOTE In Norway, due to regulation for CATV-installations, and in Sweden, a galvanic isolator shall provide electrical insulation below 5 MHz. The insulation shall withstand a dielectric strength of 1,5 kV r.m.s., 50 Hz or 60 Hz, for 1 min.</p> <p>Translation to Norwegian (the Swedish text will also be accepted in Norway): "Apparater som er koplet til beskyttelsesjord via nettplugg og/eller via annet jordtilkøpet utstyr – og er tilkøpet et koaksialbasert kabel-TV nett, kan forårsake brannfare. For å unngå dette skal det ved tilkøpling av apparater til kabel-TV nett installeres en galvanisk isolator mellom apparatet og kabel-TV nettet."</p> <p>Translation to Swedish: "Apparater som är kopplad till skyddsjord via jordat vägguttag och/eller via annan utrustning och samtidigt är kopplad till kabel-TV nät kan i vissa fall medföra risk för brand. För att undvika detta skall vid anslutning av apparaten till kabel-TV nät galvanisk isolator finnas mellan apparaten och kabel-TV nätet."</p>	Not television equipment.	N/A

IEC62368_1D - ATTACHMENT			
Clause	Requirement + Test	Result - Remark	Verdict
5.7.6.2	<p>Denmark</p> <p>To the end of the subclause the following is added: The warning (marking safeguard) for high touch current is required if the touch current or the protective current exceed the limits of 3,5 mA .</p>		N/A
B.3.1 and B.4	<p>Ireland and United Kingdom</p> <p>The following is applicable: To protect against excessive currents and short-circuits in the primary circuit of direct plug-in equipment, tests according to Annexes B.3.1 and B.4 shall be conducted using an external miniature circuit breaker complying with EN 60898-1, Type B, rated 32A. If the equipment does not pass these tests, suitable protective devices shall be included as an integral part of the direct plug-in equipment, until the requirements of Annexes B.3.1 and B.4 are met</p>	Not direct plug-in equipment.	N/A
G.4.2	<p>Denmark</p> <p>To the end of the subclause the following is added: Supply cords of single phase appliances having a rated current not exceeding 13 A shall be provided with a plug according to DS 60884-2-D1:2011. CLASS I EQUIPMENT provided with socket-outlets with earth contacts or which are intended to be used in locations where protection against indirect contact is required according to the wiring rules shall be provided with a plug in accordance with standard sheet DK 2-1a or DK 2-5a. If a single-phase equipment having a RATED CURRENT exceeding 13 A or if a poly-phase equipment is provided with a supply cord with a plug, this plug shall be in accordance with the standard sheets DK 6-1a in DS 60884-2-D1 or EN 60309-2. Mains socket outlets intended for providing power to Class II apparatus with a rated current of 2,5 A shall be in accordance DS 60884-2-D1:2011 standard sheet DKA 1-4a. Other current rating socket outlets shall be in compliance with Standard Sheet DKA 1-3a or DKA 1-1c. Mains socket-outlets with earth shall be in compliance with DS 60884-2-D1:2011 Standard Sheet DK 1-3a, DK 1-1c, DK1-1d, DK 1-5a or DK 1-7a <i>Justification:</i> Heavy Current Regulations, Section 6c</p>	No such parts.	N/A

IEC62368_1D - ATTACHMENT			
Clause	Requirement + Test	Result - Remark	Verdict
G.4.2	<p>United Kingdom</p> <p>To the end of the subclause the following is added: The plug part of direct plug-in equipment shall be assessed to BS 1363: Part 1, 12.1, 12.2, 12.3, 12.9, 12.11, 12.12, 12.13, 12.16, and 12.17, except that the test of 12.17 is performed at not less than 125 °C. Where the metal earth pin is replaced by an Insulated Shutter Opening Device (ISOD), the requirements of clauses 22.2 and 23 also apply.</p>	Not direct plug-in equipment.	N/A
G.7.1	<p>United Kingdom</p> <p>To the first paragraph the following is added: Equipment which is fitted with a flexible cable or cord and is designed to be connected to a mains socket conforming to BS 1363 by means of that flexible cable or cord shall be fitted with a 'standard plug' in accordance with the Plugs and Sockets etc (Safety) Regulations 1994, Statutory Instrument 1994 No. 1768, unless exempted by those regulations.</p> <p>NOTE "Standard plug" is defined in SI 1768:1994 and essentially means an approved plug conforming to BS 1363 or an approved conversion plug.</p>	No such parts.	N/A
G.7.1	<p>Ireland</p> <p>To the first paragraph the following is added: Apparatus which is fitted with a flexible cable or cord shall be provided with a plug in accordance with Statutory Instrument 525: 1997, "13 A Plugs and Conversion Adapters for Domestic Use Regulations: 1997. S.I. 525 provides for the recognition of a standard of another Member State which is equivalent to the relevant Irish Standard</p>	No such parts.	N/A
G.7.2	<p>Ireland and United Kingdom</p> <p>To the first paragraph the following is added: A power supply cord with a conductor of 1,25 mm² is allowed for equipment which is rated over 10 A and up to and including 13 A.</p>	No such parts.	N/A

IEC62368_1D - ATTACHMENT			
Clause	Requirement + Test	Result - Remark	Verdict

ZC	ANNEX ZC, NATIONAL DEVIATIONS (EN)		—
10.5.2	<p>Germany</p> <p>The following requirement applies: For the operation of any cathode ray tube intended for the display of visual images operating at an acceleration voltage exceeding 40 kV, authorization is required, or application of type approval (Bauartzulassung) and marking.</p> <p><i>Justification:</i> German ministerial decree against ionizing radiation (Röntgenverordnung), in force since 2002-07-01, implementing the European Directive 96/29/EURATOM.</p> <p>NOTE Contact address: Physikalisch-Technische Bundesanstalt, Bundesallee 100, D-38116 Braunschweig, Tel.: Int +49-531-592-6320, Internet: http://www.ptb.de</p>	No such parts.	N/A

-- End of Attachment 1 --

Attachment 2 Photographs



Overall view

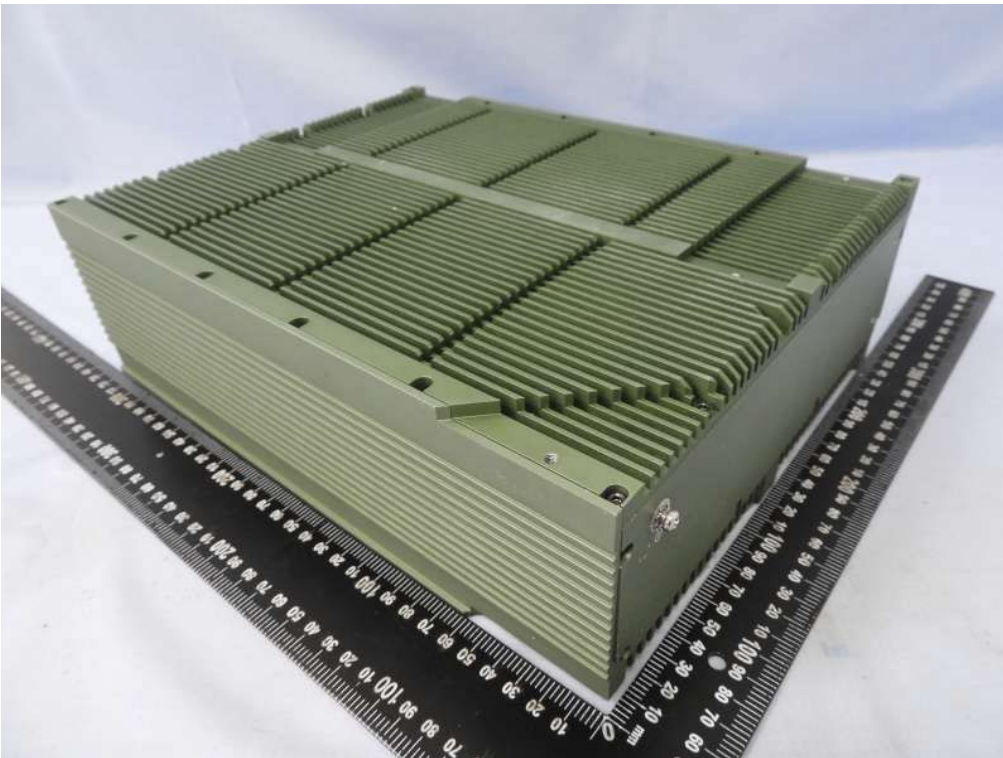

Overall view

Attachment 2 Photographs



Overall view

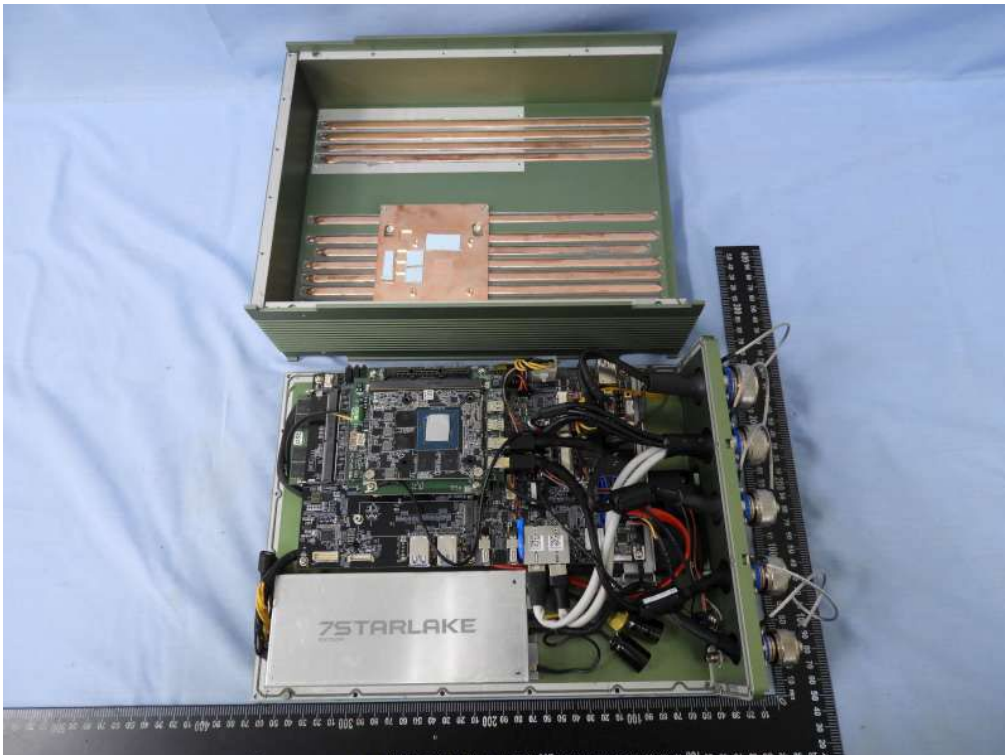

Internal view

Attachment 2 Photographs

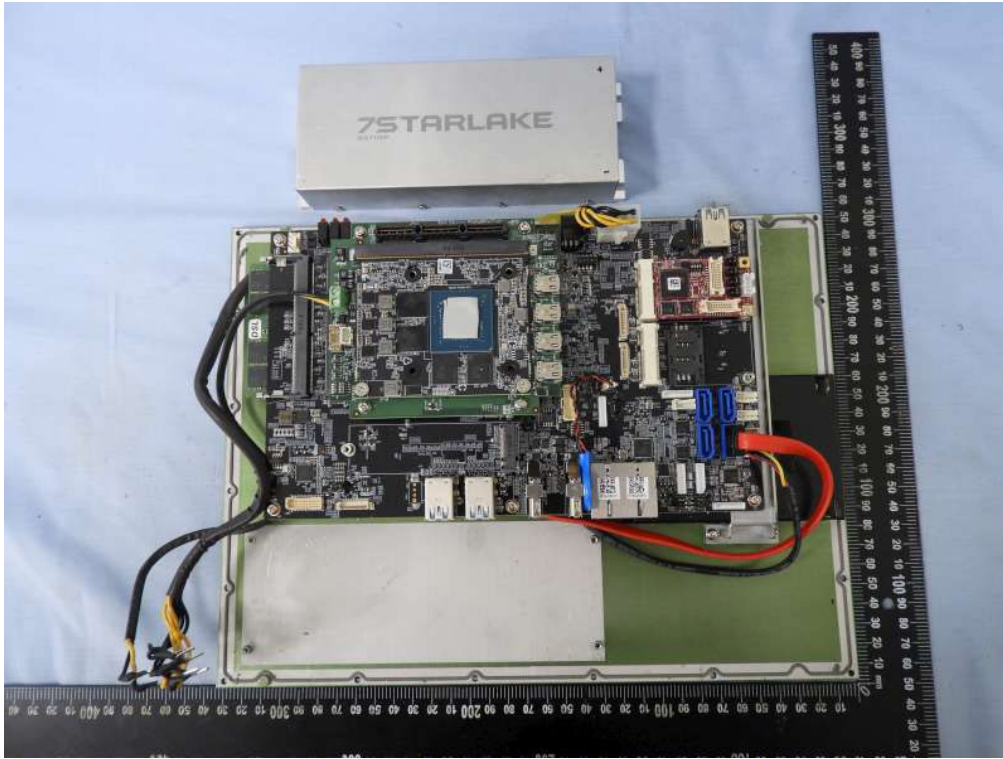

Internal view

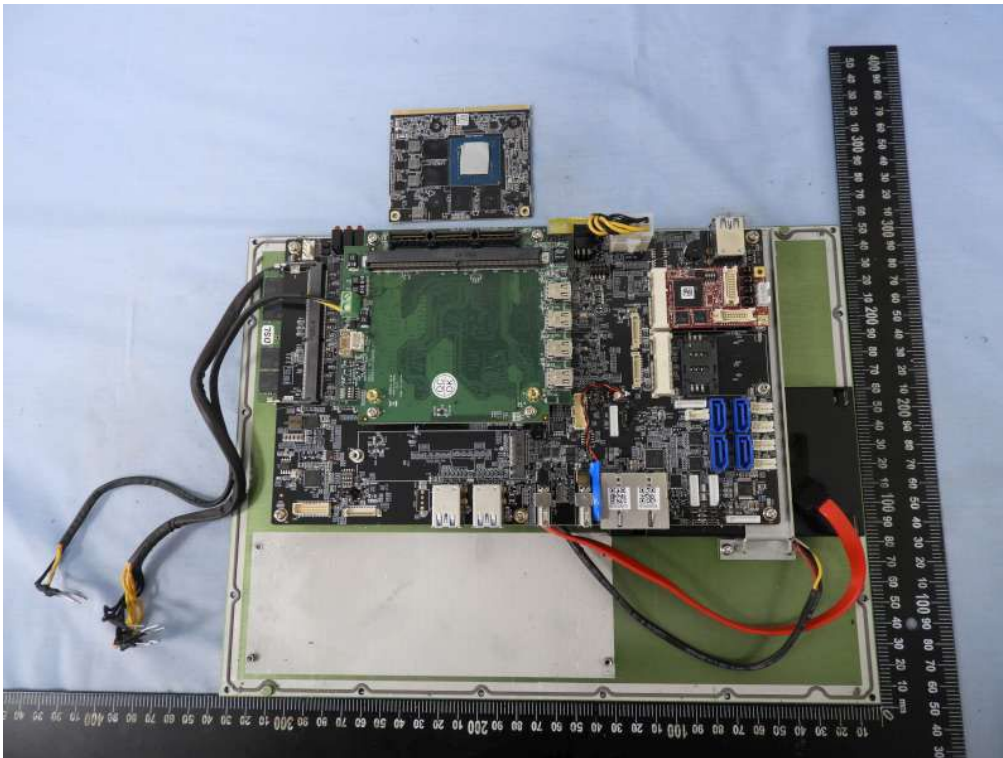

Internal view

Attachment 2 Photographs

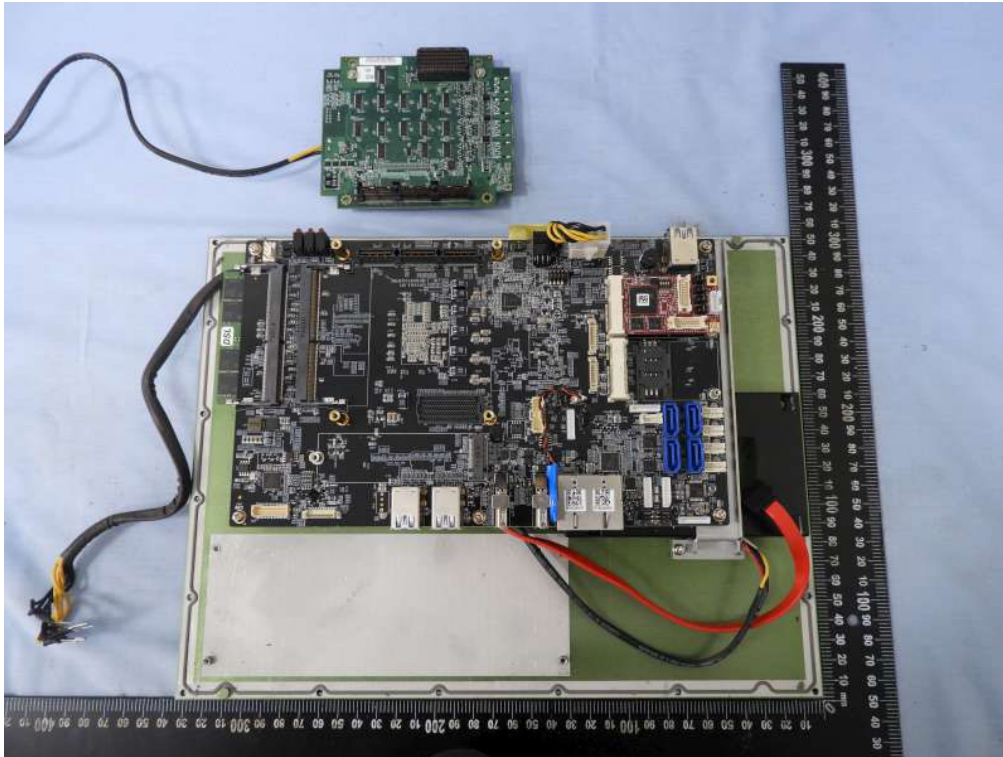

Internal view

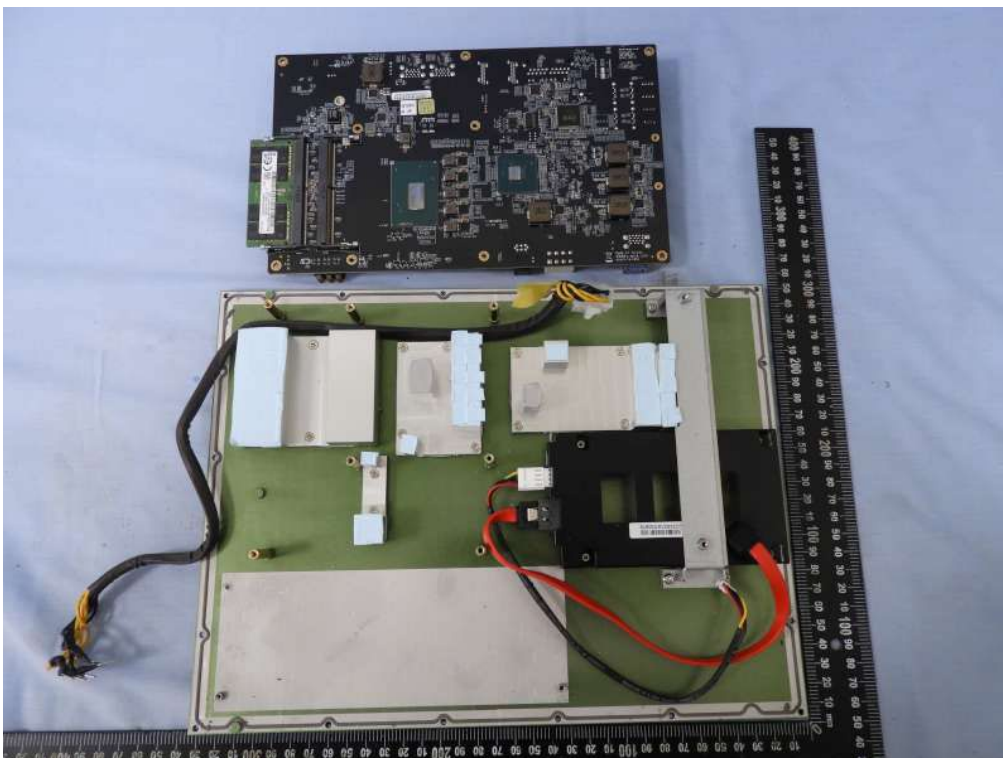

Internal view

Attachment 2 Photographs

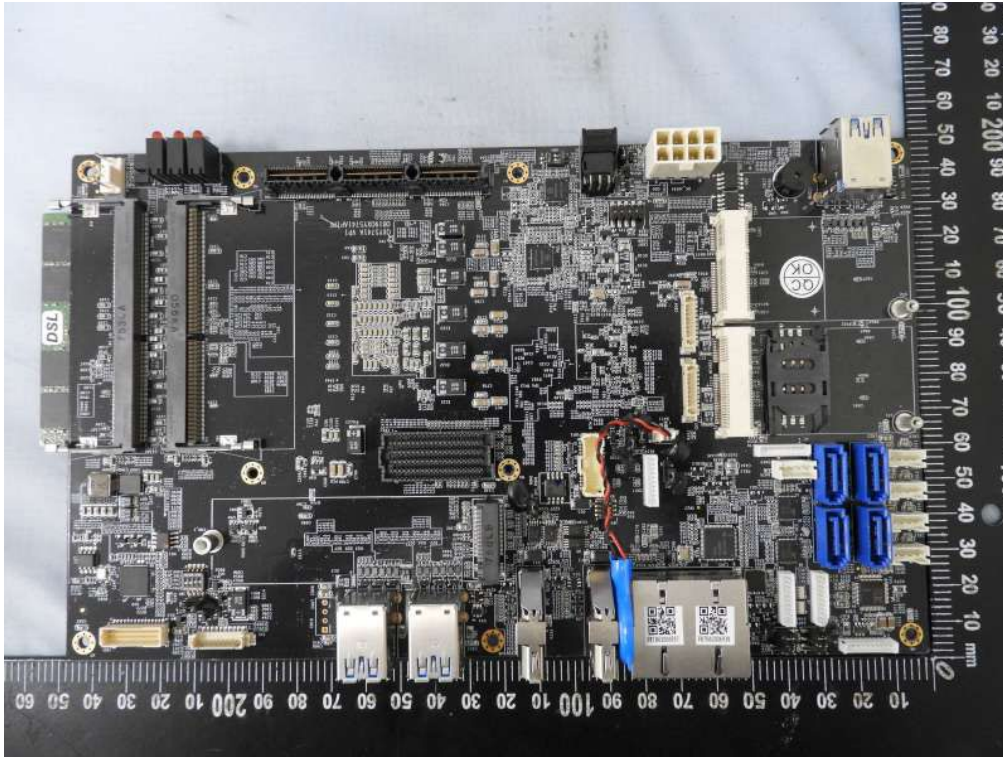

Main board

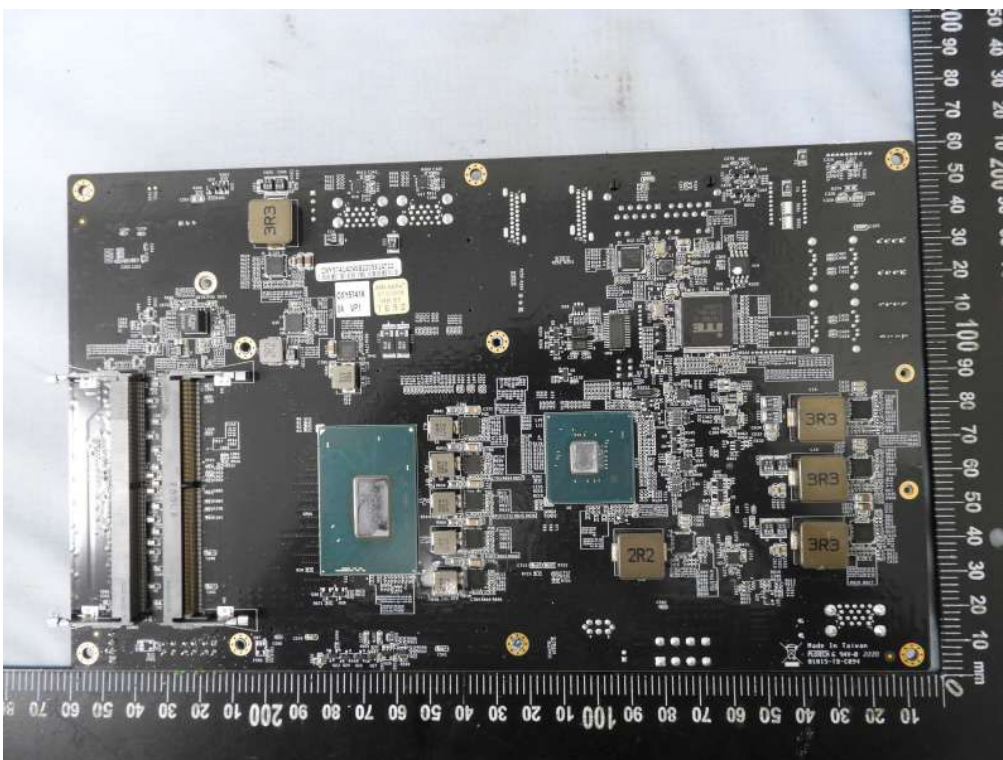

Main board

Attachment 2 Photographs

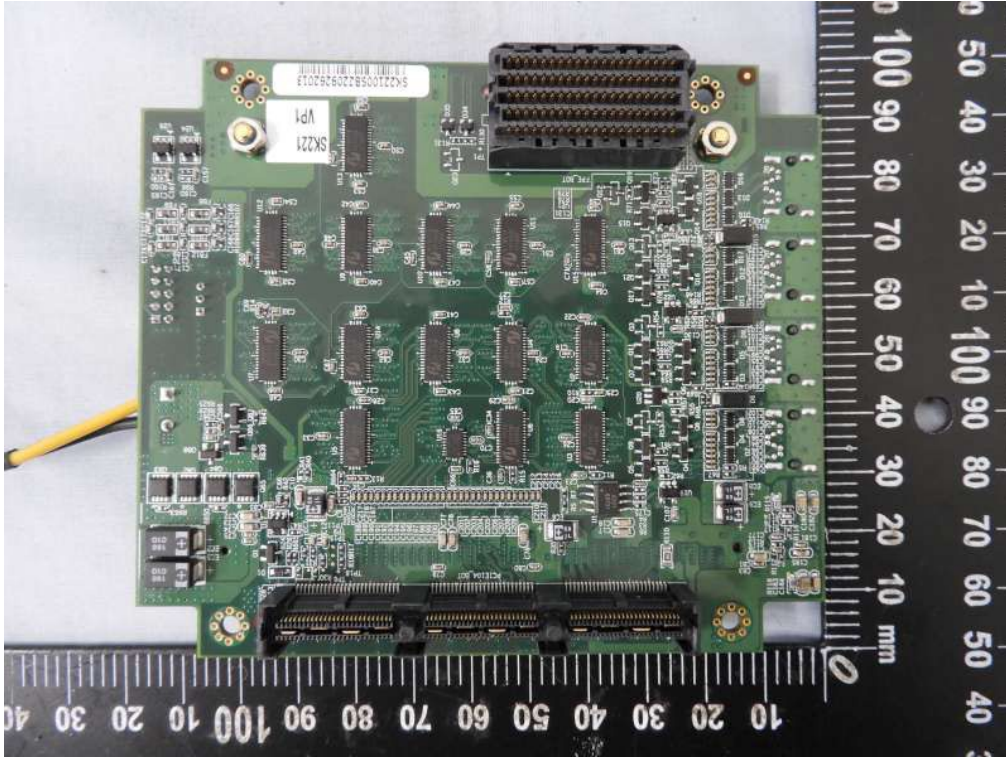

Connect board



Connect board

Attachment 2 Photographs

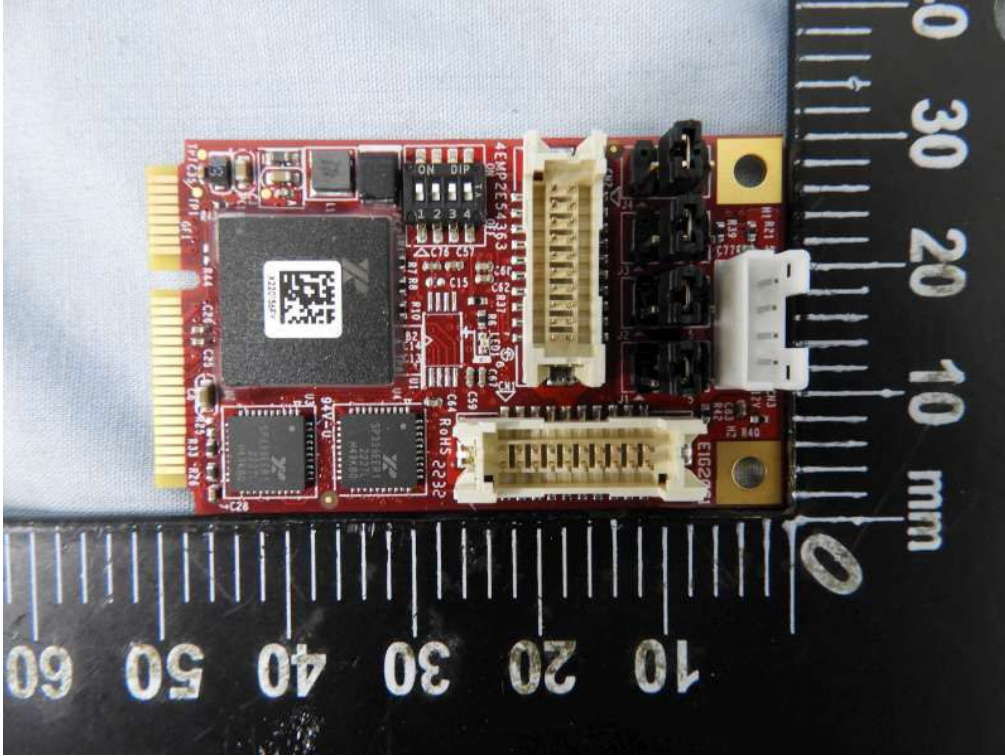

I/O board

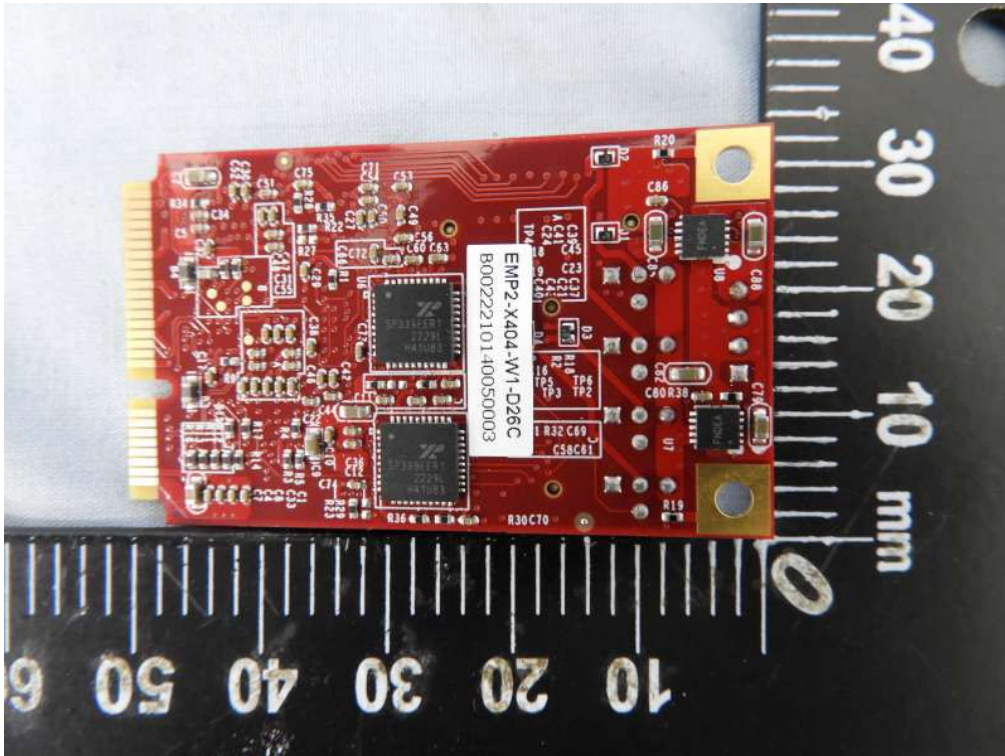

I/O board

Attachment 2 Photographs

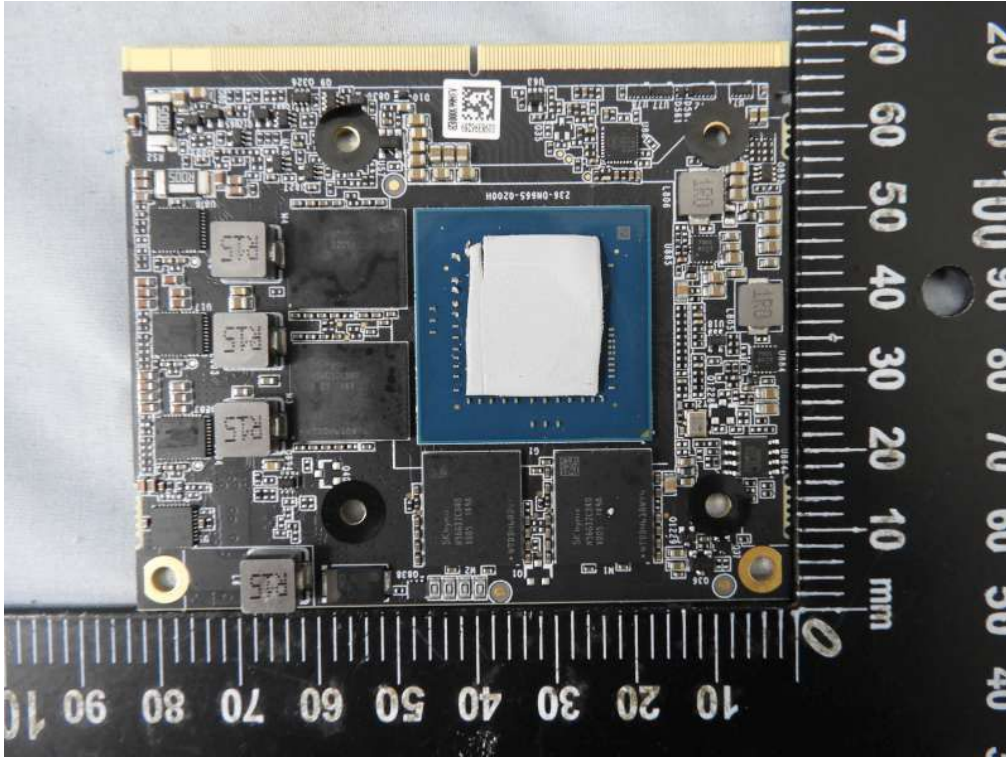

DATA board

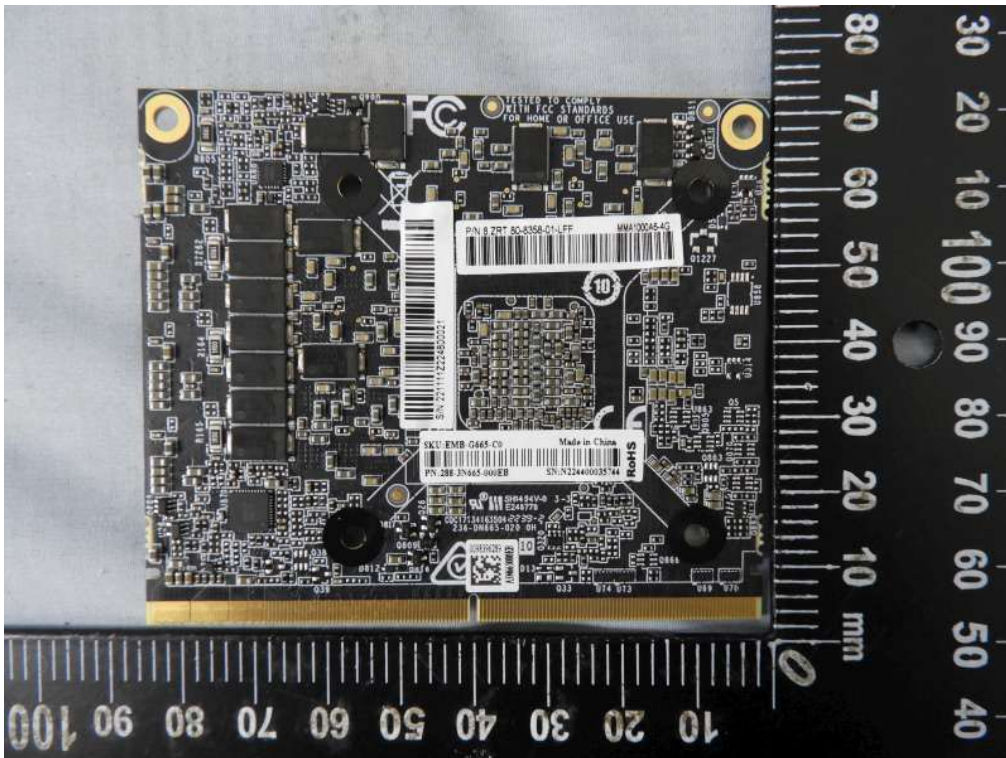

DATA board

-- End of Attachment 2 --