



# F40

Refer 1/2 Short ATR (Customization)



- MIL-STD810 Thermal, shock, vibration, Humidity / EMI / EMC conditions
- 9th / 8th Gen Intel® Xeon® / Core™ processor
- IP65 Chassis with D38999 connectors
- Memory support up to DDR4-128GB
- 1 x 2.5" Easy swap HDD/SSD Tray
- MIL-STD-704 / MIL-STD-461/ MIL-STD-1275
- 10V~40V DC-Input for optional
- High performance with lower power efficiency (total power consumption under 150W)

# Specifications

## System

High Power Processor	Intel® Core™ i7-9850HE Processor (up to 4.40 GHz), 45W Intel® Core™ i7-9850HL Processor (up to 4.10 GHz), 25W Intel® Xeon® E-2276ME Processor (up to 4.50 GHz), 45W Intel® Xeon® E-2276ML Processor (up to 4.20 GHz), 25W
Memory type	Support up to DDR4-128GB ,ECC for Xeon SKU
Chipset	CM246
Graphic	Intel® UHD Graphics 630
BIOS	AMI UEFI BIOS
ARINC 429 (optional)	6 Channels of ARINC-429 Channels: 4 RX/TX and 2 RX Only Channels. w/ mini-PCIe card (Alta-dt MPCIE-A429)
MIL -1553(optional)	1-2 INDEPENDENT, DUAL REDUNDANT (A/B) MIL-STD-1553 CHANNELS w/ mini-PCIe card (Alta-dt MPCIE2-1553)
TPM	TPM 2.0 (SLB9665)
M.2	1 x M.2 (M-key, Type: 2280 , SATA/PCIe 3.0 x 4 NVMe)
Mini PCIe	2 x Full size (USB / PCIe and 1 x micro SIM Card)
Ethernet	1 x Intel I210-IT / 1 x I219-LM GbE
Power Type	10V ~ 40V DC IN
Storage	1 x 2.5" Easy swap HDD/SSD Tray
GPIO	4x GPIO
Operating Temperature	-40 to +60 C
Dimension	123.95(W) x 177(L) x 286.25(H) mm

## FRONT I/O

X1	3 x RS232 + 3 x RS422/RS485 + 2 x USB 2.0 + 4 x 1GbE LAN with 100 PIN D38999 connector
X2	1 x USB3.0 with USB3.0 D38999 connector
X3	1 x Mini DP with D38999 connector
X4	2 x DVI +1 x VGA with 50PIN D38999 connector
X5	1 x DC in with D38999 connector

others	1 x 2.5" Easy swap HDD/SSD Tray 4 x SDI connectors
<b>Environmental</b>	
MIL-STD-810 Test	<b>Method 500.5, Procedures I and II (Altitude, Operation):</b> 12,192M, (40,000 ft) for the initial cabin altitude (18.8Kpa or 2.73 Psia) <b>Method 500.5, Procedures III and IV (Altitude, Non-Operation):</b> 15,240, (50,000 ft) for the initial cabin altitude (14.9Kpa or 2.16 Psia) Method 501.5, Procedure I (Storage/High Temperature) Method 501.5, Procedure II (Operation/High Temperature) Method 502.5, Procedure I (Storage/Low Temperature) Method 502.5, Procedure II (Operation/Low Temperature) Method 503.5, Procedure I (Temperature shock) Method 507.5, Procedure II (Temperature & Humidity) Method 514.6, Vibration Category 24/Non-Operating (Category 20 & 24,Vibration) Method 514.6, Vibration Category 20/Operating (Category 20 & 24,Vibration) Method 516.6, Shock-Procedure V Non-Operating (Mechanical Shock) Method 516.6, Shock-Procedure I Operating (Mechanical Shock)
Reliability	No Moving Parts; Passive Cooling. Designed & Manufactured using ISO 9001 Certified Quality Program.
EMC	MIL-STD-461 : CE102 basic curve, 10kHz - 30 MHz RE102-4, (1.5 MHz) -30 MHz - 5 GHz RS103, 200 MHz - 3.2 GHz, 50 V/m equal for all frequencies EN 61000-4-2: Air discharge: 8 kV, Contact discharge: 6kV EN 61000-4-3: 10V/m EN 61000-4-4: Signal and DC-Net: 1 kV EN 61000-4-5: Leads vs. ground potential 1kV, Signal und DC-Net: 0.5 kV CE and FCC

# Block Diagram

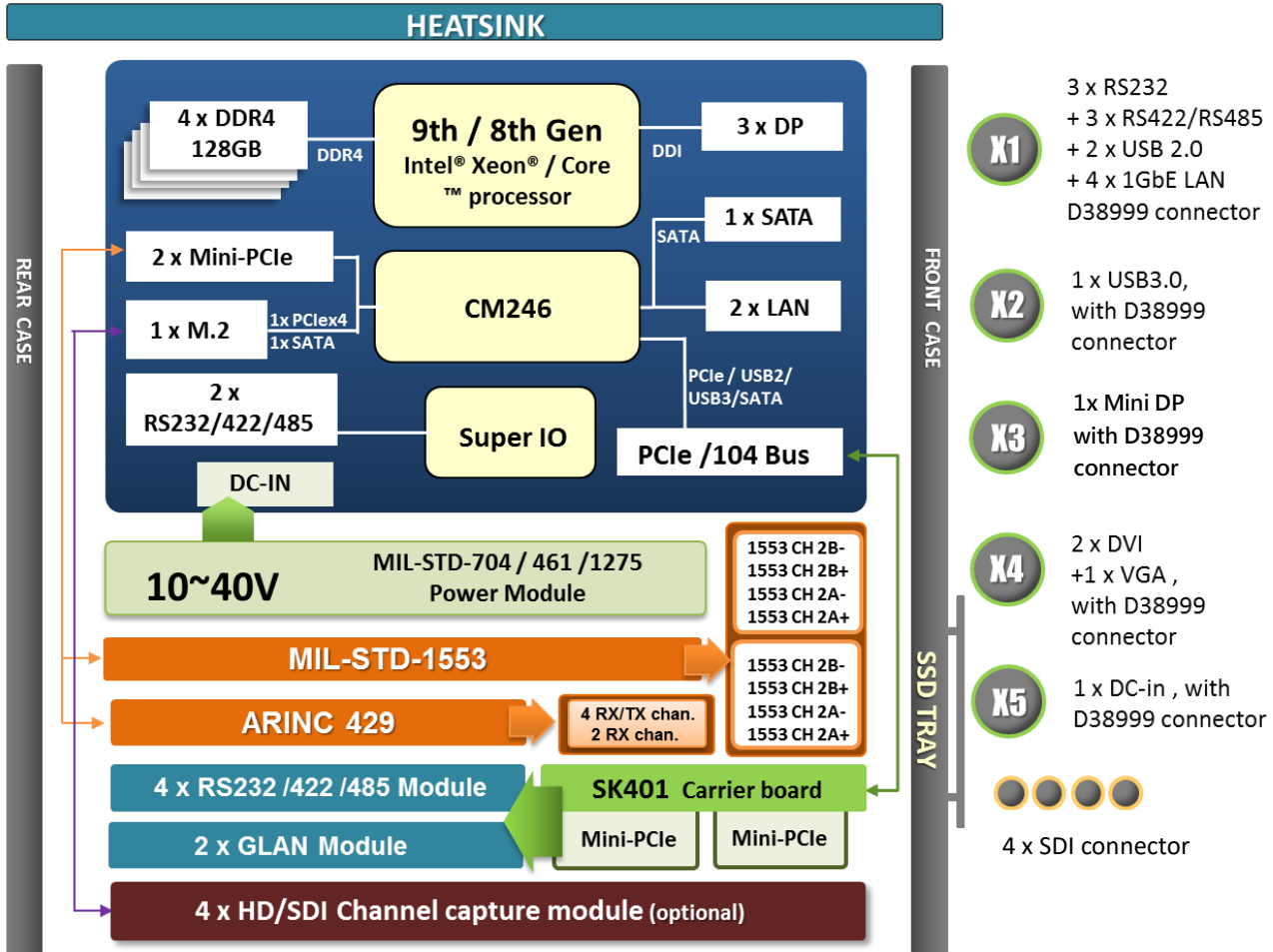

# Appearance

